

WNFQ-268AXI(BT)

WiFi 6/6E 2x2 MU-MIMO

802.11ax/ac/a/b/g/n Tri-band 2.4GHz/5GHz/6GHz

Industrial-Grade, 2T2R Wi-Fi+Bluetooth 5.2 M.2 module



Industrial-Grade Wi-Fi +Bluetooth Combo Solution M.2 Module

WNFQ-268AXI(BT), first Qualcomm based WiFi-6E (802.11ax) module in M.2 2230 E key formfactor, running PCIe (Wifi) and USB (Bluetooth), supports DBDC (Dual-band, Dual-concurrent) mode, but with Tri-band capability (2.4GHz, 5GHz, and 6GHz). WNFQ-268AXI(BT) is able to concurrently run 2.4GHz with 5GHz, or 6GHz, and support full IEEE802.11 ax/ac/a/b/g/n protocol, up to 160MHz mode.

WNFQ-268AXI(BT) designed with 2 spatial streams (2T2R, or 2x2) in MU-MIMO mode. With a standard M.2 E key 2230 formfactor, WNFQ-268AXI(BT) can accommodate to all existing platform that has M.2 Adaptor pre-integrated, no extra work with platform design.

Software wise WNFQ-268AXI(BT) support Windows, with Linux (Open Source) in the near future. The module is capable to run on both x86 platform and ARM based platform, and supports STA mode and Soft AP Mode*, recommend to run on application includes: digital signage/POS, rugged computer / tablets, fanless automation PC and other industrial environment applications that requires high speed data transmission.

Embedded Application

Applications include IPC/ Advertising machine/ OTT/ IPTV/ DVB/ STB / DV/ Mini Driving Recorder/ Intelligent Projector Pico/ VR/ AR terminal/ POS machine/ Vehicle mounted front/ Rear Terminal UAV/ Robot/ Intelligent Gateway/ Smart city and other electronic products.

Key Feature

- Compliant with IEEE 802.11 ax/ac/a/b/g/n
- Supports 2x2 Multi-User Multiple-Input Multiple-Output (MU-MIMO)
- Dual Band Simultaneous (DBS), up to 3.6 Gbps data rate (2x2+2x2 11ax DBS)
- Tri-band 2.4 GHz/5 GHz/6 GHz support
- 20 MHz/40 MHz channel bandwidth for 2.4 GHz and 20 MHz/40 MHz/80 MHz/160 MHz channel bandwidth for 5 GHz/6 GHz

Specification

Standards	IEEE 802.11ax/ac/a/b/g/n (2T2R) Bluetooth V5.2, V5.1, V5.0, V4.2, V4.1, V4.0LE, V3.0, V2.1+EDR
Chipset	Qualcomm Atheros WCN6856
Data Rate	802.11b: 11Mbps 802.11a/g: 54Mbps 802.11n: MCS0~15 802.11ac: MCS0~9 802.11ax: MCS0~13 Bluetooth: 1 Mbps, 2Mbps and Up to 3Mbps
Operating Frequency	IEEE 802.11ax/ac/a/b/g/n ISM Band, 2.412GHz~2.484GHz, 5.150GHz~5.850GHz ,5.925~7.125GHz *Subject to local regulations
Interface	WLAN: PCIe Bluetooth: USB
Form Factor	M.2 2230 E Key
Antenna	2 x IPEX MHF4 connectors Ant 1 for WLAN/BT, Ant 2 for WLAN
Modulation	Wi-Fi: 802.11b: DSSS (DBPSK, DQPSK, CCK) 802.11g: OFDM (BPSK, QPSK, 16-QAM, 64-QAM) 802.11n: OFDM (BPSK, QPSK, 16-QAM, 64-QAM) 802.11a: OFDM (BPSK, QPSK, 16-QAM, 64-QAM) 802.11ac: OFDM (BPSK, QPSK, 16-QAM, 64-QAM, 256-QAM) 802.11ax: OFDMA (BPSK, QPSK, 16-QAM, 64-QAM, 256-QAM, 1024-QAM, 2048QAM,4096QAM) BT: Header: GFSK Payload 2M: $\pi/4$ -DQPSK Payload 3M: 8-DPSK
Power Consumption	TX mode: 632 mA (Average) RX mode: 378 mA (Average)
Operating Voltage	DC 3.3V
Operating Temperature Range	-40°~+85°C (Operating)
Storage Temperature Range	-45°C~90°C

Humidity (Non-Condensing)	5%~90% (Operating) 5%~90% (Storing)
Dimension L x W x H (in mm)	30mm(± 0.15mm) x 22mm(± 0.15mm) x 3.5mm(± 0.3mm)
Weight (g)	3.2g
Driver Support	Windows 10,11/ Linux (Open Source)
Security	64/128-bits WEP, WPA, WPA2, WPA3, 802.1x

OUTPUT POWER & SENSITIVITY		
802.11b		
Data Rate	Tx \pm 2dBm	Rx Sensitivity
11Mbps	18 dBm	\leq -90 dBm

802.11g		
Data Rate	Tx \pm 2dBm	Rx Sensitivity
54Mbps	17.5 dBm	\leq -76.5 dBm

802.11n / 2.4GHz				
	Data Rate	Tx \pm 2dBm (1TX)	Tx \pm 2dBm (2TX)	Rx Sensitivity
HT20	MCS7	16 dBm	19 dBm	\leq -73dBm
	MCS7	16 dBm	19 dBm	\leq -71 dBm

802.11a		
Data Rate	Tx \pm 2dBm	Rx Sensitivity
54Mbps	17.5 dBm	\leq -77dBm

802.11n / 5GHz				
	Data Rate	Tx \pm 2.5dBm (1TX)	Tx \pm 2.5dBm (2TX)	Rx Sensitivity
HT20	MCS7	16 dBm	19 dBm	\leq -76 dBm
	MCS7	15.5 dBm	18.5 dBm	\leq -73 dBm

802.11ac				
	Data Rate	Tx \pm 2.5dBm (1TX)	Tx \pm 2.5dBm (2TX)	Rx Sensitivity
VHT80	MCS9	15 dBm	18 dBm	\leq -62 dBm
VHT160	MCS9	14 dBm	17dBm	\leq -58 dBm

802.11ax / 2.4 GHz				
	Data Rate	Tx \pm 2dBm (1TX)	Tx \pm 2dBm (2TX)	Rx Sensitivity
HE40	MCS11	16 dBm	19 dBm	\leq -60 dBm

802.11ax / 5GHz				
	Data Rate	Tx \pm 2.5dBm (1TX)	Tx \pm 2.5dBm (2TX)	Rx Sensitivity
HE20	MCS11	12.5 dBm	15.5 dBm	\leq -64.5 dBm
	MCS11	12 dBm	15 dBm	\leq -63.5 dBm

HE80	MCS11	10 dBm	13 dBm	≤ -59 dBm
HE160	MCS11	10 dBm	13 dBm	≤ -56.5 dBm

802.11ax / 6GHz				
HE20	Data Rate	Tx \pm 2.5dBm (1TX)	Tx \pm 2.5dBm (2TX)	Rx Sensitivity
	MCS11	10.5 dBm	13.5 dBm	≤ -63 dBm
HE40	MCS11	10 dBm	13 dBm	≤ -61 dBm
HE80	MCS11	9.5 dBm	12.5 dBm	≤ -58 dBm
HE160	MCS11	8 dBm	11 dBm	≤ -55 dBm

Bluetooth		
Data Rate	Tx \pm 2dBm (Class 1 Device)	Rx Sensitivity
3Mbps	$0 \leq$ Output Power ≤ 14 dBm	<0.1% BR, BER at -70dBm

Block Diagram

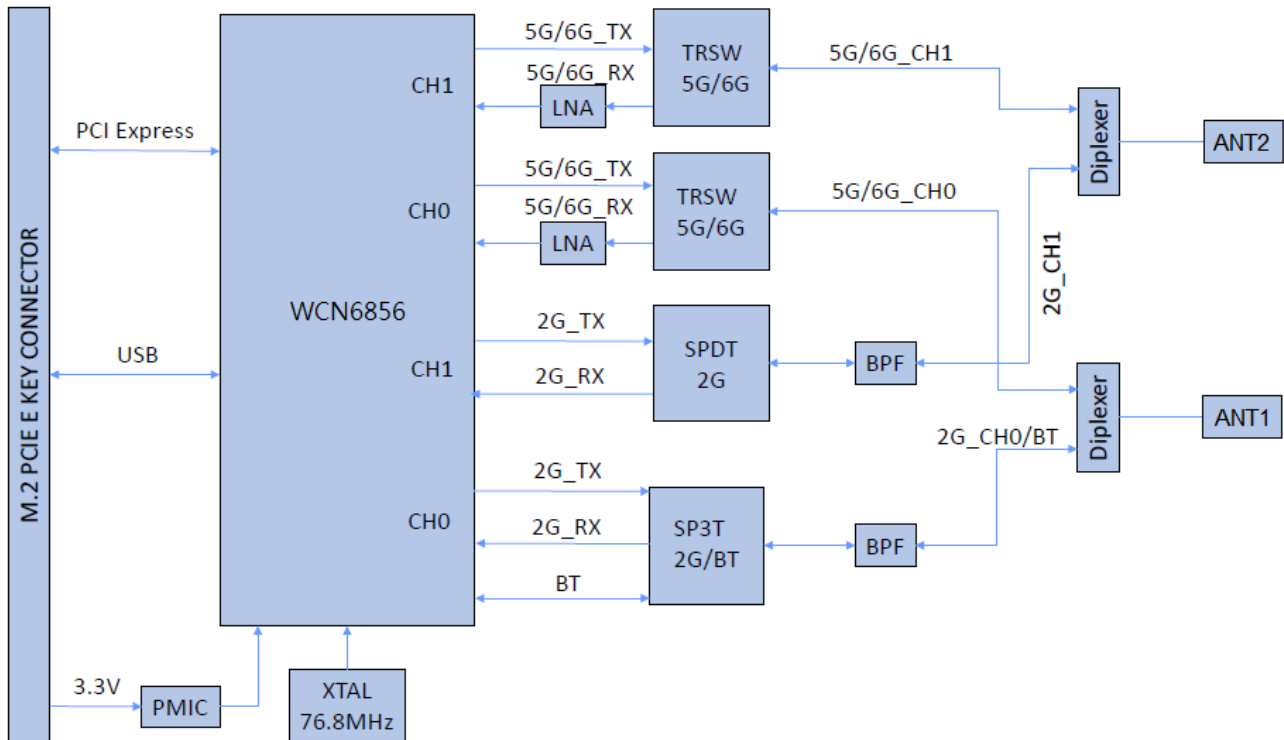

Mechanical Dimension (mm)

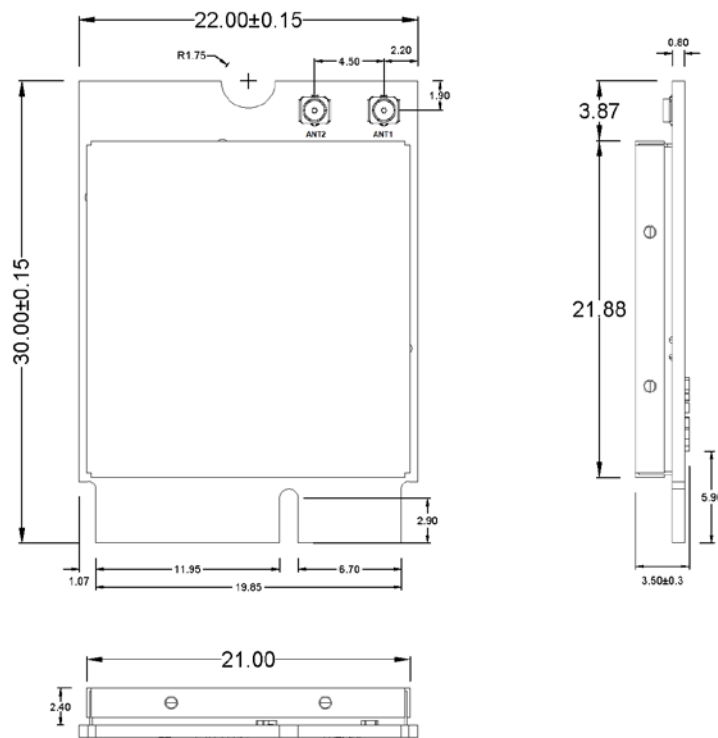

MHF4 connector spec.

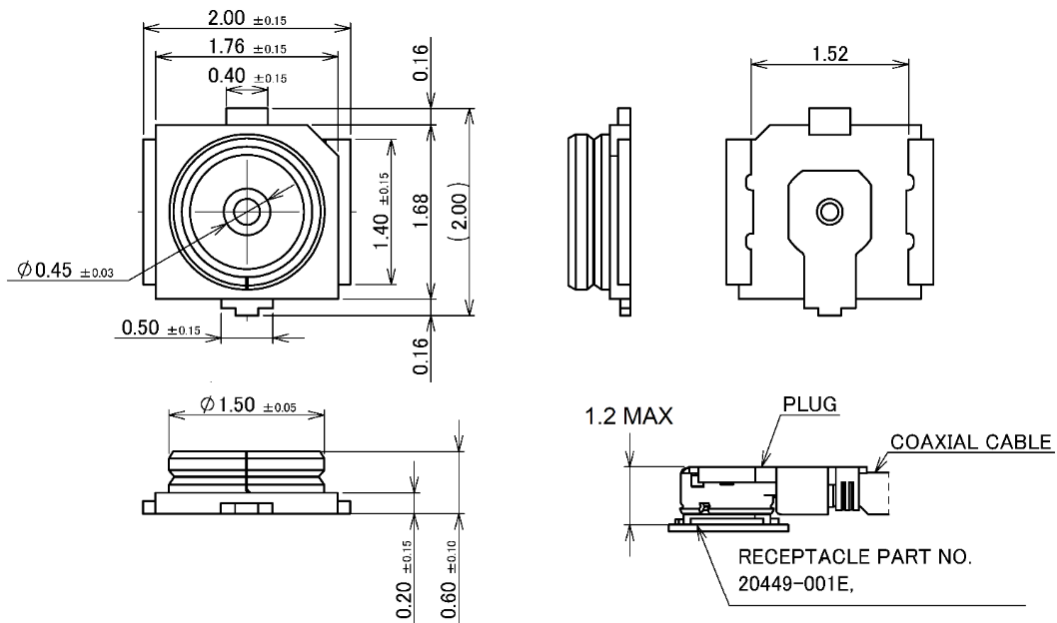

Unit: mm

Pin Assignment

The following section illustrate signal pin-outs for the module connector.

TOP			
Pin#	Pin Name	Type	Description
1	GND	G	Ground connections
3	USB_D+	I/O	USB serial differential data Positive
5	USB_D-	I/O	USB serial differential data Negative
7	GND	G	Ground connections
9	SDIO_CLK/SYSCLK	NC	No Connection
11	SDIO_CMD	NC	No Connection
13	SDIO_DATA0	NC	No Connection
15	SDIO_DATA1	NC	No Connection
17	SDIO_DATA2	NC	No Connection
19	SDIO_DATA3	NC	No Connection
21	SDIO_WAKE#	NC	No Connection
23	SDIO_RESET#/TX_BLANKING	NC	No Connection
25	NOTCH FOR KEY E	NC	No Connection

TOP			
Pin#	Pin Name	Type	Description
27	NOTCH FOR KEY E	NC	No Connection
29	NOTCH FOR KEY E	NC	No Connection
31	NOTCH FOR KEY E	NC	No Connection
33	GND	G	Ground connections
35	PERp0	I	PCI Express receive data-Positive
37	PERn0	I	PCI Express receive data-Negative
39	GND	G	Ground connections
41	PETp0	O	PCI Express transmit data- Positive
43	PETn0	O	PCI Express transmit data- Negative
45	GND	G	Ground connections
47	REFCLKp0	I	PCI Express differential clock input- Positive
49	REFCLKn0	I	PCI Express differential clock input- Negative
51	GND	G	Ground connections
53	CLKREQ0# (3.3V)	OD	PCIe clock request
55	PEWAKE0# (3.3V)	OD	PCIe wake signal
57	GND	G	Ground connections
59	RESERVED/PERp1	NC	No Connection
61	RESERVED/PERn1	NC	No Connection
63	GND	G	Ground connections
65	RESERVED/PETp1	NC	No Connection
67	RESERVED/PETn1	NC	No Connection
69	GND	G	Ground connections
71	RESERVED/REFCLKp1	NC	No Connection
73	RESERVED/REFCLKn1	NC	No Connection
75	GND	G	Ground connections

Pin Assignment

The following section illustrate signal pin-outs for the module connector.

BOTTOM			
Pin#	Pin Name	Type	Description
2	3.3 V	P	VDD system power supply input
4	3.3 V	P	VDD system power supply input
6	LED_1#	O	No Function
8	I2S_SCK (1.8V)	I	I2S Continuous Serial Clock (SCK).

BOTTOM			
Pin#	Pin Name	Type	Description
10	I2S_WS (1.8V)	I	I2S Word Select.
12	I2S_SD_OUT (1.8V)	O	I2S Serial Data IN.
14	I2S_SD_IN (1.8V)	I	I2S Serial Data OUT.
16	LED_2#	O	No Function
18	GND	G	Ground connections
20	UART_WAKE# (3.3V)	NC	No Connection
22	UART_TXD	NC	No Connection
24	NOTCH FOR KEY E	NC	No Connection
26	NOTCH FOR KEY E	NC	No Connection
28	NOTCH FOR KEY E	NC	No Connection
30	NOTCH FOR KEY E	NC	No Connection
32	UART_RXD	NC	No Connection
34	UART_RTS	NC	No Connection
36	UART_CTS	NC	No Connection
38	VENDOR DEFINED	NC	No Connection
40	VENDOR DEFINED	NC	No Connection
42	VENDOR DEFINED	NC	No Connection
44	COEX3	NC	No Connection
46	COEX_TXD	DNC	Do Not Connect
48	COEX_RXD	DNC	Do Not Connect
50	SUSCLK	NC	No Connection
52	PERST0#	I	PCIe host indication to reset the device Active low.
54	W_DISABLE2#	I	BT enable signal. (This pin is floating. Please set W_DISABLE2# pin to pull high on the platform side.)
56	W_DISABLE1#	I	Reserved for W_DISABLE1 (This pin is floating. Please set W_DISABLE1# pin to pull high on the platform side.)
58	I2C_DATA	NC	No Connection
60	I2C_CLK	NC	No Connection
62	ALERT#	NC	No Connection
64	RESERVED	NC	No Connection
66	UIM_SWP/PERST1#	NC	No Connection
68	UIM_POWER_SNK/CLKREQ1#	NC	No Connection
70	UIM_POWER_SRC/GPIO_1/PEWAKE1#	NC	No Connection
72	3.3 V	P	VDD system power supply input
74	3.3 V	P	VDD system power supply input

Note: Power (P), Ground (G), Open-Drain (OD), Input (I), Output (O), Do Not Connect (DNC), No Connection (NC)

Certification

- FCC
- IC
- NCC
- CE (RED EN 300 328 V2.2.2 / EN 301 893 V2.1.1)
- MIC
- ASNZS

Ordering Information

Product Name	Part Number	Description
WNFQ-268AXI(BT)	R9701A10004	11ax/ac/a/b/g/n Industrial Grade 2T2R Wi-Fi+BT M.2 Module

Optional Accessory

Product Name	Part Number	Description
AD-103AG	R3410110203	Dipole Antenna, 2dBi 2.4GHz/5GHz, RP-SMA(M) connector
AD-302N	R3410110221	Dipole Antenna, 3dBi/2dBi 2.4G/5GHz, RP-SMA(M) connector
AD-303N	R3410110222	Dipole Antenna, 3dBi/3dBi 2.4G/5GHz, RP-SMA(M) connector
AD-500AX	R3410A14050	Dipole Antenna, 2.65dBi/4.98dBi/4.98dBi 2.4G/5G/6GHz, I-PEX / MHF4 connector
AD-501AX	R3410A10050	Dipole Antenna, 3.7dBi/5dBi/5dBi 2.4G/5G/6GHz, RP-SMA(M) connector
AD-502AX	R3410A34050	PIFA Antenna, 3.5dBi/5dBi/3.9dBi 2.4G/5G/6GHz, I-PEX / MHF4L connector
AD-503AX	R3410A44050	Dipole Antenna, 3.7dBi/5dBi/5dBi 2.4G/5G/6GHz, I-PEX / MHF4L connector
CBIRF-NE150	R3470300025	RF Cable, I-PEXMHF4 to RP-SMA(F); L150mm; Coaxial 0.81 Black
CBIRF-NE250	R3470300026	RF Cable, I-PEXMHF4 to RP-SMA(F); L250mm; Coaxial 0.81 Black