

4.3” WQVGA**High brightness color TFT-LCD Module****Model: VM04B1 V6****Date: Oct. 12nd, 2021****Version: 01****Note: This specification is subject to change
without notice****Customer :** _____**Date :** _____**Approved****Prepared****Date:****Date:**

Contents

- 1. Handling Precautions**
- 2. General Description**
 - 2.1 Overview
 - 2.2 Features
 - 2.3 Application
 - 2.4 Display specifications
 - 2.5 Optical characteristics
- 3. Absolute Maximum Ratings**
 - 3.1 TFT LCD module
 - 3.2 Backlight unit
 - 3.3 Environment
- 4. Electrical Characteristics**
 - 4.1 TFT LCD module
 - 4.2 Backlight unit
 - 4.3 Interface connector
- 5. Timing characteristics**
 - 5.1 Power On/Off Sequence
 - 5.2 AC Characteristic
 - 5.3 Parallel 24-bit RGB timing table
 - 5.4 Display mode select
- 6. Reliability Test**
- 7. Shipping package**
- 8. Mechanical Characteristics**

RECORD OF REVISION

Version and Date	Page	Old description	New description	Remark
0.1 2021/10/12	All	First Edition for customer		

1. Handling Precautions

- 1) Since front polarizer is easily damaged, pay attention not to scratch it.
- 2) Be sure to turn off power supply when inserting or disconnecting from input connector.
- 3) Wipe off water drop immediately. Long contact with water may cause discoloration or spots.
- 4) When the panel surface is soiled, wipe it with absorbent cotton or other soft cloth.
- 5) Since the panel is made of glass, it may break or crack if dropped or bumped on hard surface.
- 6) Since CMOS LSI is used in this module, take care of static electricity and insure human earth when handling.
- 7) Do not open or modify the Module Assembly.
- 8) Do not press the reflector sheet at the back of the module to any directions.
- 9) At the insertion or removal of the Signal Interface Connector, be sure not to rotate nor tilt the Interface Connector of the TFT Module.
- 10) After installation of the TFT Module into an enclosure, do not twist nor bend the TFT Module even momentary. At designing the enclosure, it should be taken into consideration that no bending/twisting forces are applied to the TFT Module from outside. Otherwise, the TFT Module may be damaged.

2. General Description

2.1 Overview

This specification applies to the Color Active Matrix Liquid Crystal Display composed of a TFT-LCD display a LED backlight system. The screen format is intended to support 480(H) x 272(V) screen and 16.7M colors.

2.2 Features

- High brightness display, 500nits by LED backlight.
- Wide operation temperature range
- Long operation lifetime BLU design
- RoHS Compliance

2.3 Application

Industrial applications.

2.4 Display specifications

Items	Unit	Specification
Screen Diagonal	mm	4.3 inch
Active Area	mm	95.04(H) X 53.86(V)
Pixels H x V	pixels	480 x3(RGB) x 272
Pixels Pitch	um	198 (per one triad) x 198
Pixel Arrangement		RGB Vertical stripe
Display mode		Normally white, TN
White luminance (center)	Cd/m ²	500 (Typ.)
Contrast ratio		350 (Typ.)
Optical Response Time	msec	25ms (Tr+Tf)
Normal Input Voltage VDD	Volt	3.3
Power Consumption (Vcc Line + LED backlight)	Watt	0.736W TFT power: 0.066W; BLU power: 0.670W
Weight	Grams	TBD
Physical size	mm	105.5(W)x67.20(H)x3(D)
Electrical Interface		TTL, 24bit Parallel RGB
Support colors		16.7M colors
Surface Treatment		Anti-glare and hard-coating 3H
Driver IC		ST7282
View direction		12 O'clock
Temperature range		
Operating	°C	-20 ~ 70
Storage	°C	-30 ~ 70
RoHS Compliance		RoHS Compliance

2.5 Optical characteristics

The following optical characteristics are measured under stable condition at 25 °C

Items	Unit	Conditions	Min.	Typ	Max.	Note
Viewing angle	Deg.	Horizontal (Right)		70		2
		CR=10 (Left)		70		
		Vertical (Up)		50		
		CR=10 (Down)		70		
Contrast Ratio		Normal Direction	250	350		3
Response Time	msec	Raising + Falling		25		4
Color / Chromaticity Coordinates (CIE)		Red x	-0.05	TBD	+0.05	5
		Red y		TBD		
		Green x		TBD		
		Green y		TBD		
		Blue x		TBD		
		Blue y		TBD		
Color coordinates (CIE) White		White x		TBD		
		White y		TBD		
Center Luminance	Cd/m ²		400	500		6
Luminance Uniformity	%		70	75		7
Crosstalk (in 60 Hz)	%				1.5	
Flicker	dB				-20	

Note 1: Measurement method

The LCD module should be stabilized at given temperature for 0.5 hour to avoid abrupt temperature change during measuring. In order to stabilize the luminance, the measurement should be executed after lighting Backlight for 1 hour in a windless room.

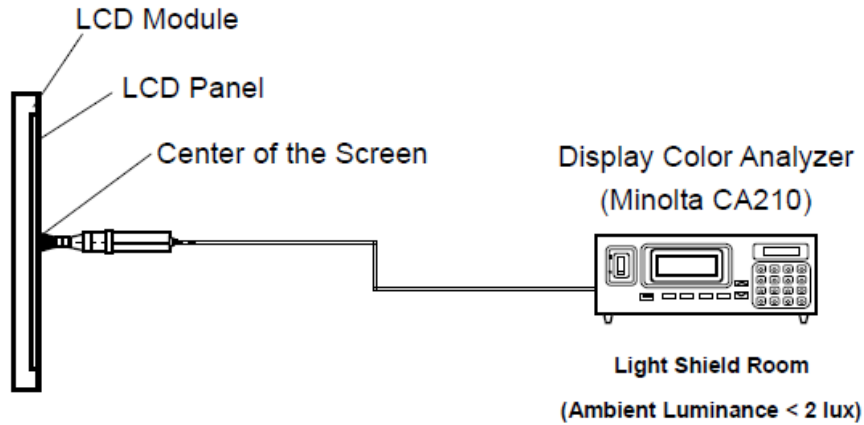

Note 2: Definition of viewing angle

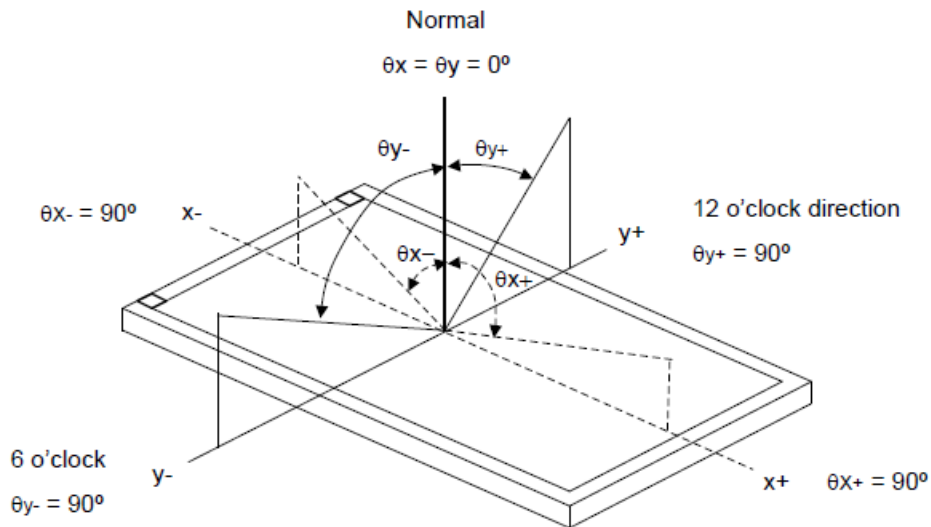

Note 3: Contrast ratio is measured by Minolta CA210

Note 4: Definition of Response time

The output signals of photo detector are measured when the input signals are changed from “Full Black” to “Full White” (rising time), and from “Full White” to “Full Black” (falling time), respectively. The response time is interval between the 10% and 90% of amplitudes. Please refer to the figure as below.

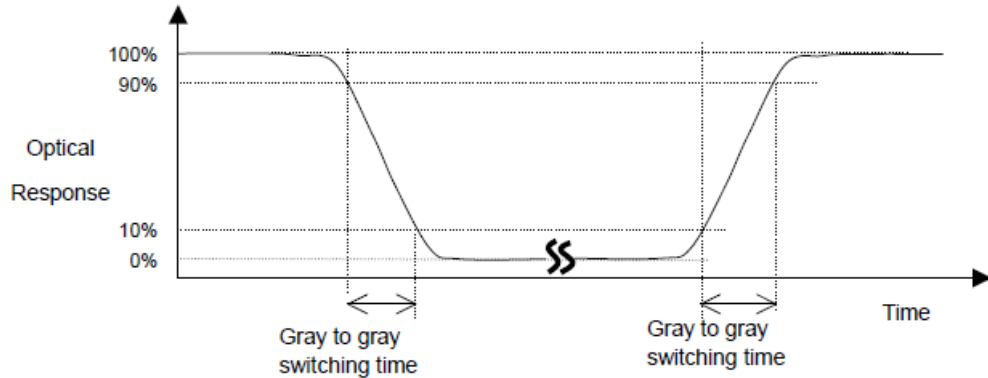

Note 5: Color chromaticity and coordinates (CIE) is measured by Minolta CA210

Note 6: Center luminance is measured by Minolta CA210

Note 7: Luminance uniformity of these 5 points is defined as below and measured by Minolta CA210



$$\text{Uniformity} = (\text{Min. Luminance of 5 points}) / (\text{Max. Luminance of 5 points})$$

3. Absolute Maximum Ratings

Absolute maximum ratings of the module are as following:

3.1 TFT LCD module

Items	Symbol	Min	Max	Unit	Conditions
Logic supply voltage	V _{IN}	-0.5	4.6	Volt	Note 1, 2

3.2 Backlight unit

Items	Symbol	Min	Max	Unit	Conditions
LED forward Voltage			19.2	V	

3.3 Environment

Items	Symbol	Values			Unit	Conditions
		Min.	Typ.	Max.		
Operation temperature	T _{OP}	-20	-	70	°C	Note 3
Operation Humidity	H _{OP}	10		85	%	
Storage temperature	T _{ST}	-30		70	°C	
Storage Humidity	H _{ST}	10		90	%	

Note 1: With in Ta= 25°C

Note 2: Permanent damage to the device may occur if exceed maximum values

Note 3: For quality performance, please refer to IIS (Incoming Inspection Standard).

4. Electrical Characteristics

4.1 TFT LCD module

Item	Symbol	Values			Unit	Note
		Min.	Typ.	Max.		
Power Voltage	DVDD	3.0	3.3	3.6	V	
	VGH	13	15	16	V	
	VGL	-11	-10	-8	V	
	ViH	0.7VCC		VCC	V	Note1
	ViL	0		0.3VCC	V	
Current of power supply	Icc	-	12.5	-	mA	
	IGH		0.1		mA	
	IGL		0.1		mA	

Note 1: ViH is high level input voltage; ViL is low level input voltage.

4.2 Backlight unit

Item	Symbol	Min.	Typ.	Max.	Unit	Condition
Supply Voltage	Vf	18.0	18.6	19.2	V	If=36mA
Supply Current	If	-	36	-	mA	
Lifetime	-		20,000		hour	If=36mA
Backlight Color	white					

Note 1: The LED supply voltage is defined by the number of LED at Ta=25°C and If=36mA.

Note 2: The LED lifetime is defined as the module brightness decrease to 50% original brightness at a=25°C and If=36mA. The LED lifetime could decrease if the operation If is larger than 36mA.

4.3 Interface connector

PIN NO.	PIN NAME	DESCRIPTION
1	LED-	LED backlight (Cathode).
2	LED+	LED backlight (Anode).
3	GND	Ground.
4	VDD	Power supply& CTP Digital Power.
5~12	R0~R7	Red Data
13~20	G0~G7	Green Data
21~28	B0~B7	Blue Data
29	GND	Ground.
30	CLK	Clock
31	DISP	Display on/off
32	HSYNC	Horizontal sync input in RGB mode.
33	VSYNC	Vertical sync input in RGB mode.
34	DE	Data enable input. Active high to enable the input data bus.
35	NC	No connection
36	GND	Ground.
37	NC	No connection
38	NC	No connection
39	NC	No connection
40	NC	No connection

5. Timing characteristics

5.1 Power On/Off Sequence

To prevent the device damage from latch up, the power on/off sequence shown below must be followed.

Power On TIMING Sequence

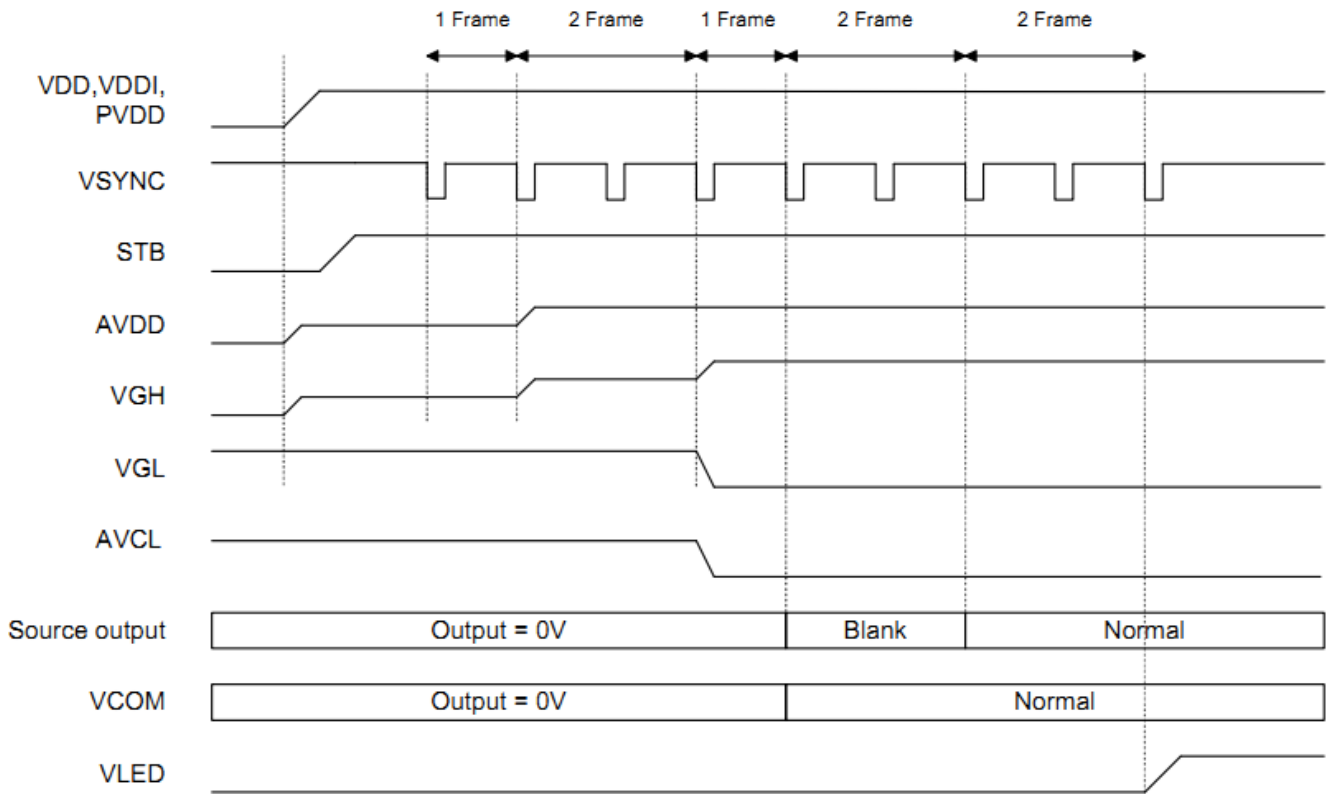

Power off timing sequence

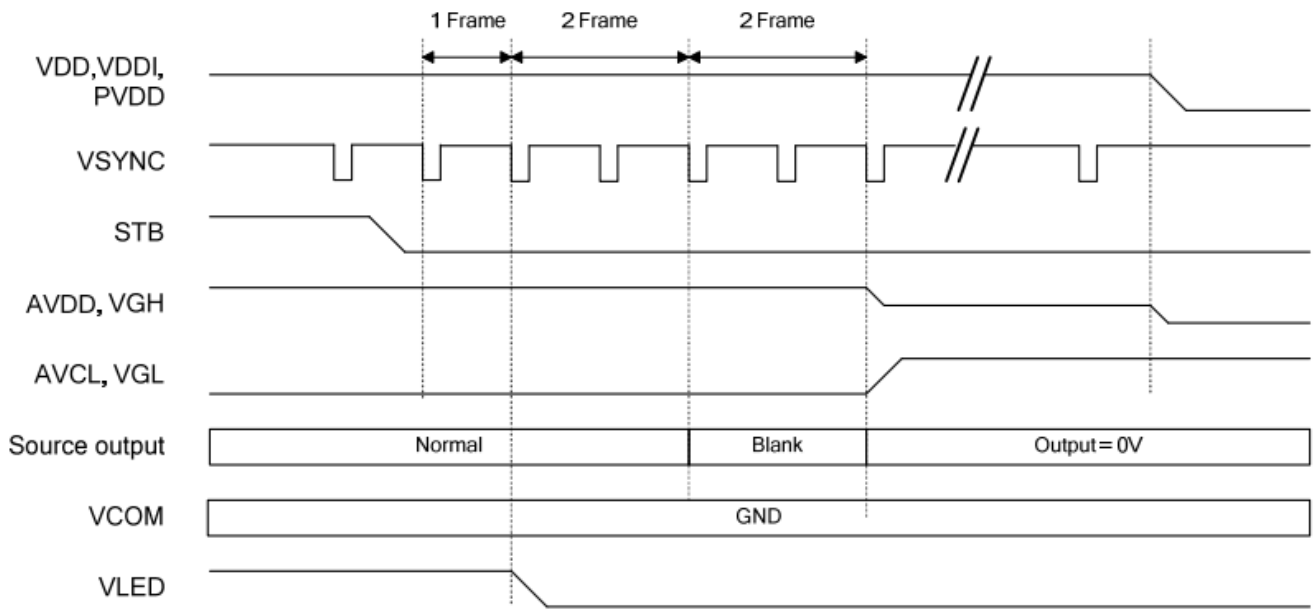

5.2AC Characteristic

Item	Symbol	Min.	Typ.	Max.	Unit	Conditions
System operation timing						
VDD power source slew time	TPOR	-	-	20	ms	From 0V to 99% VDD
GRB pulse width	tRSTW	10	50	-	us	R=10Kohm, C=1uF
Input/ Output timing						
CLK pulse duty	Tcw	40	50	60	%	
Hsync width	Thw	1	-	-	DCLK	
Hsync period	Th	55	60	65	us	
Vsync setup time	Tvst	12	-	-	ns	
Vsync hold time	Tvhd	12	-	-	ns	
Hsync setup time	Thst	12	-	-	ns	
Hsync hold time	Thhd	12	-	-	ns	
Data setup time	Tdsu	12	-	-	ns	
Data hold time	Tdhd	12	-	-	ns	
SD output stable time	Tst	-	-	12	us	Output settled within +20mV Loading = 6.8k+28.2pF.
GD output rise and fall time	Tgst	-	-	6	us	Output settled (5%-95%), Loading = 4.7k+29.8pF
3-wire serial communication						
Delay between CSB and Vsync	Tcv	1			us	
CS input setup time	Ts0	50			ns	
Serial data input setup time	Ts1	50			ns	
CS input hold time	Th0	50			ns	
Serial data input hold time	Th1	50			ns	
SCL pulse high width	Twh1	50			ns	
SCL pulse low width	Twl1	50			ns	
CS pulse high width	Tw2	400			ns	

AC Timing Diagram

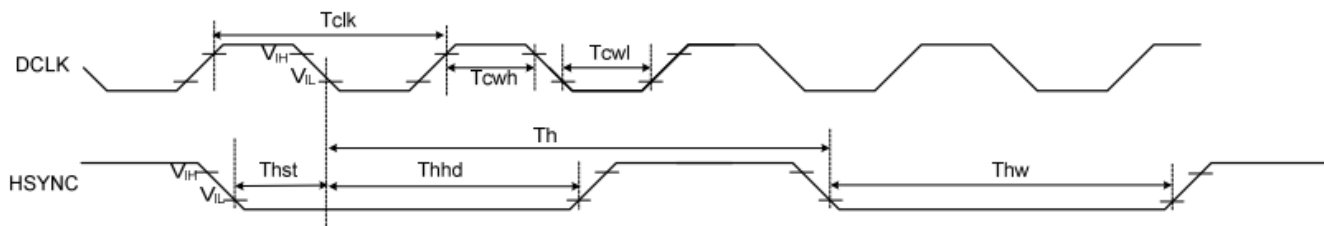
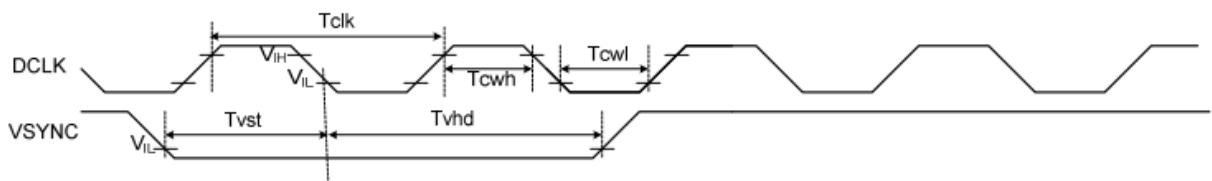

SYNC Mode

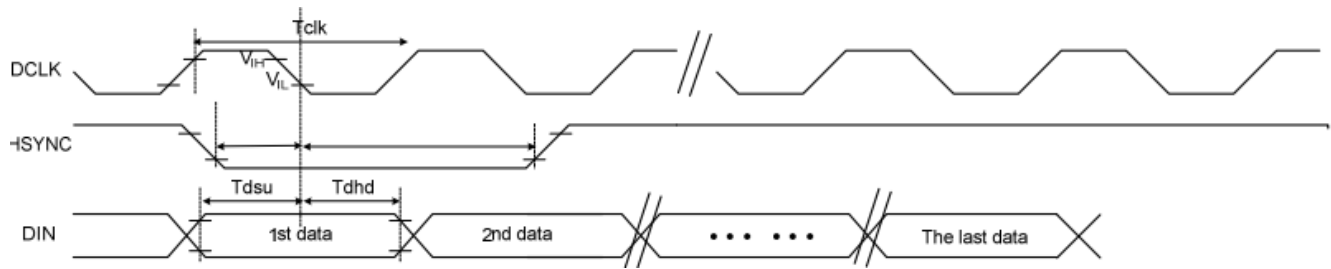

SYNC-DE Mode

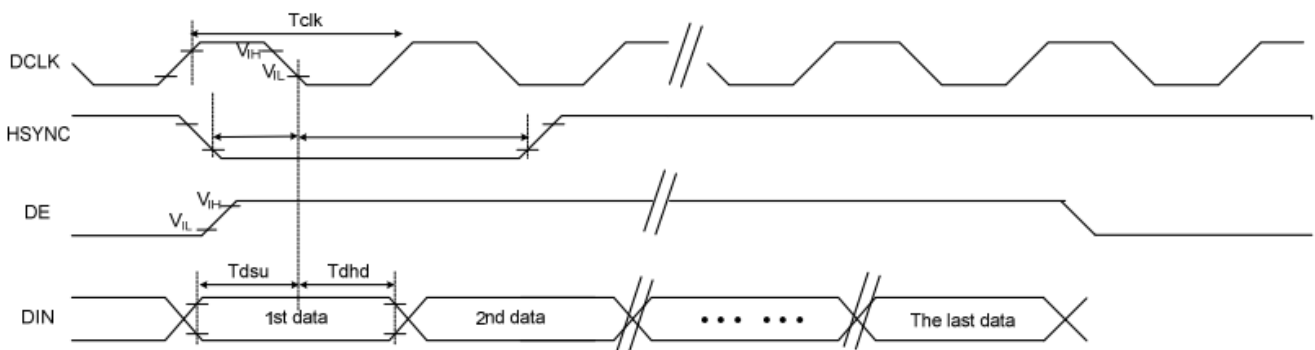

5.3 Parallel 24-bit RGB timing table

Item	Symbol	Min.	Typ.	Max.	Unit	Remark	
DCLK Frequency	Fclk	9	12	15	MHz		
DCLK Period	Tclk	67	83	111	ns		
HSYNC	Period Time	Th	486	526	533	DCLK	
	Display Period	Thdisp		480		DCLK	
	Back Porch	Thbp	3	43	50	DCLK	By H_Blanking setting
	Front Porch	Thfp	2	2	2	DCLK	
	Pulse Width	Thw	1	1	1	DCLK	
VSYNC	Period Time	Tv	276	286	304	H	
	Display Period	Tvdisp		272		H	
	Back Porch	Tvbp	2	12	30	H	By V_Blanking setting
	Front Porch	Tvfp	1	1	1	H	
	Pulse Width	Tvw	1	1	1	H	

5.4 Display mode select

SYNC Mode Timing Diagram

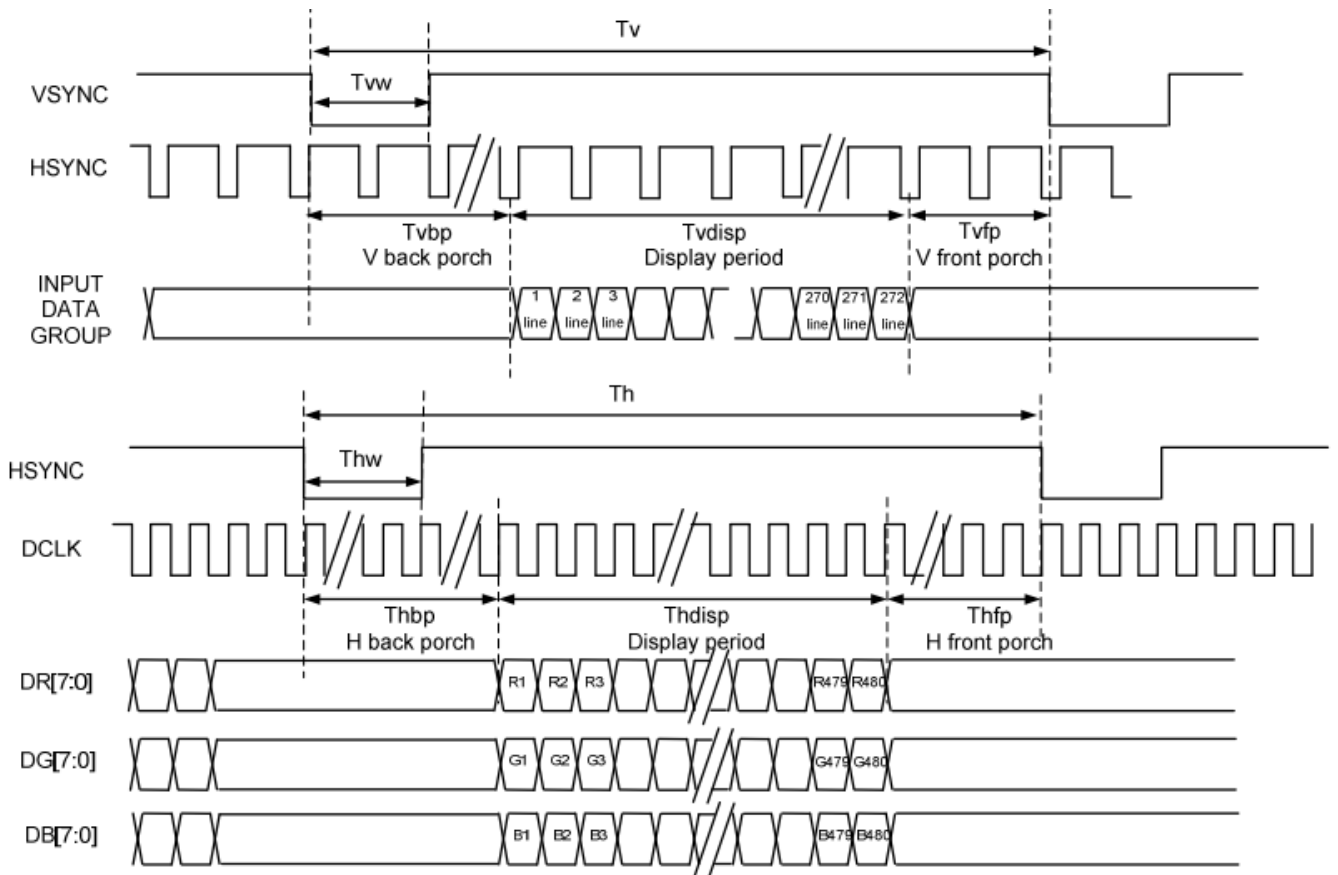

SYNC-DE Mode Timing Diagram

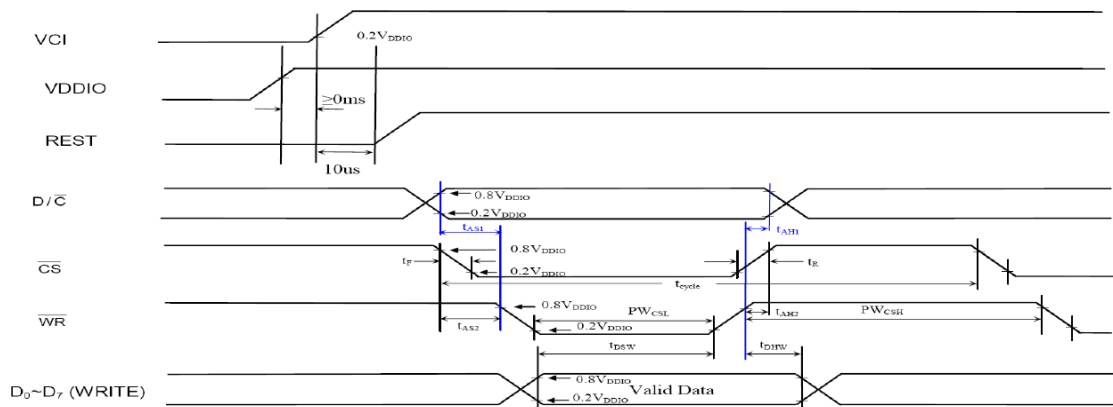
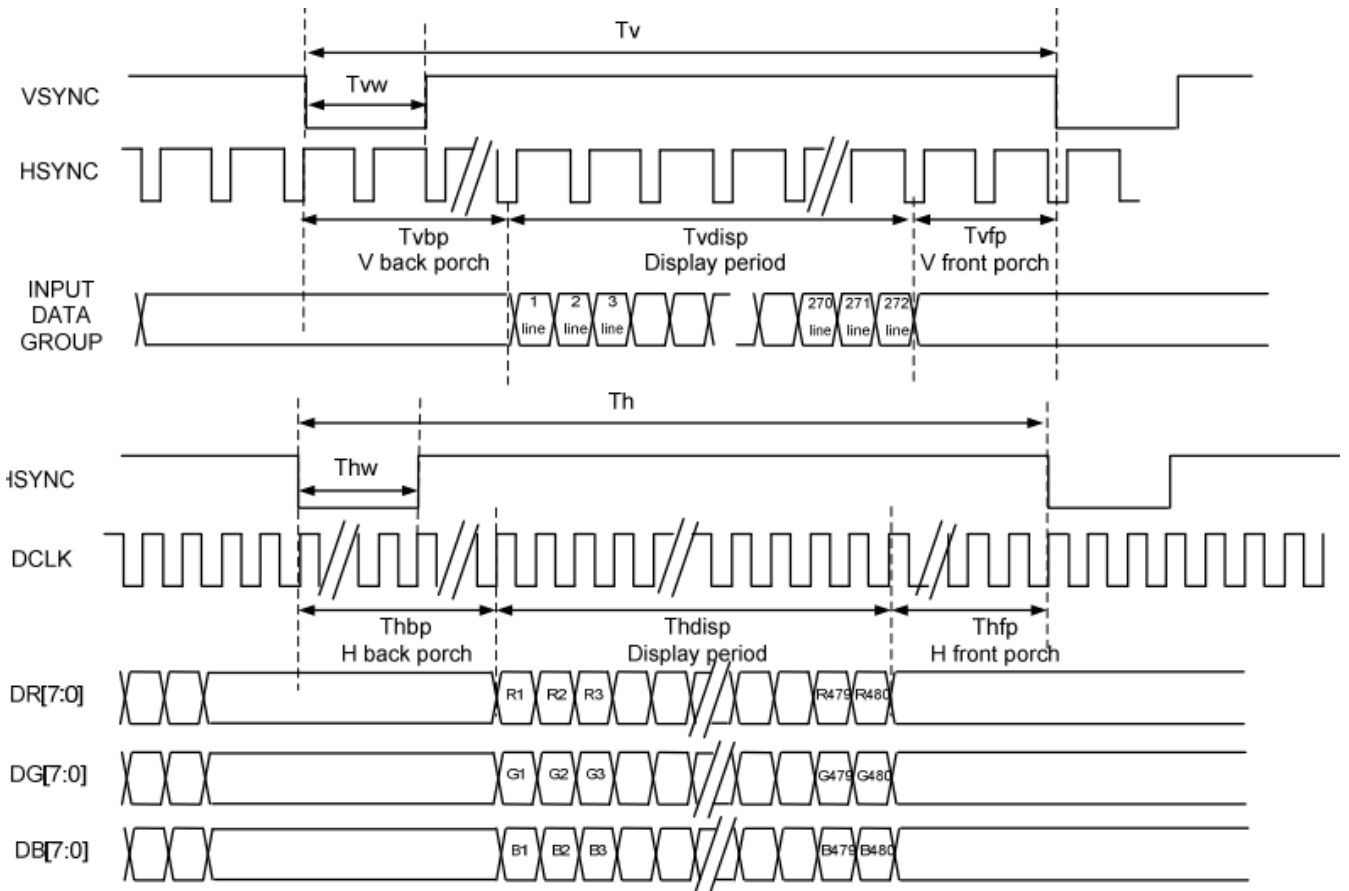

Hsync and vertical shift clock timing waveform

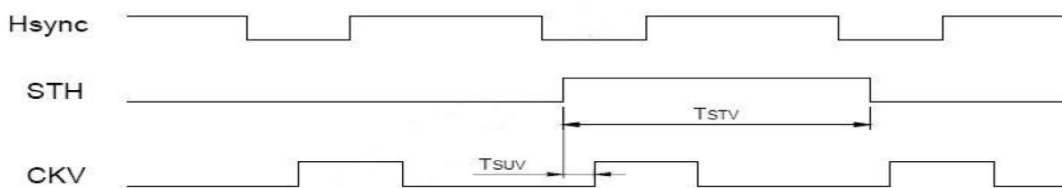

6. Reliability Test

Environment test conditions are listed as following table.

Items	Required Condition	Note
Temperature Humidity Bias (THB)	Ta=60°C, 90%RH, 48hours	
High Temperature Operation (HTO)	Ta= 70°C, 50%RH, 48hours	
Low Temperature Operation (LTO)	Ta= -20°C, 48hours	
High Temperature Storage (HTS)	Ta= 70°C, 48hours	
Low Temperature Storage (LTS)	Ta= -30°C, 48hours	
ESD (ElectroStatic Discharge)	Contact Discharge: ± 4kV Air Discharge: ± 8kV, 150pF(330Ω) 5 times/ point, 5points/panel, class B.	

Note 1: After storage temperature test, the unit is placed in normal room ambient for at least 4 hours before power on.

Note 2: In case of malfunction defect caused by ESD damage, if it would be recovered to normal state after resetting, it would be judge as a good part. Self-recoverable degradation or less of performance is acceptable.

Note 3: EL evaluation should be accepted from reliability test with humidity and temperature: Some defects such as black spot/blemish can happen by natural chemical reaction with humidity and Fluorescence EL has.

Note 4: Failure Judgment Criterion: Basic Specification Electrical Characteristic, Mechanical Characteristic, Optical Characteristic.

**7. Shipping package
(TBD)**

8. Mechanical Characteristics

NOTES:

1. DISPLAY TYPE: 262K COLOR TFT-LCD, TRANSMISSIVE, EMV wide view angle.
2. OPERATING TEMP: -20° C~70° C
3. STORAGE TEMP: -30° C~70° C
4. LCD DRIVER: ST7282 or Equal
5. BACKLIGHT: 6S2P with 12CHIP-WHITE LED
6. Luminance: 500cd/m² Min
7. () *Reference Dimension.

General Tol: ±0.2mm.

CIRCUIT DIAGRAM(6S2P)
(If=30mA, V=16.8~19.2V)

PIN DESCRIPTION

1	LEDA
2	GND
3	GND
4	VCC
5	R0
6	R1
7	R2
8	R3
9	R4
10	R5
11	R6
12	R7
13	G0
14	G1
15	G2
16	G3
17	G4
18	G5
19	G6
20	G7
21	B0
22	B1
23	B2
24	B3
25	B4
26	B5
27	B6
28	B7
29	GND
30	CLK
31	DISP
32	HSYNC
33	VSYNC
34	DEN
35	NC
36	GND
37	X(RING)
38	Y(DING)
39	X(LING)
40	Y(UNG)

REV	DESCRIPTION	DATE
B01	First Issue	10/11/2021

SHEET:	block:0F	block:1
GENERAL TOL:	block:0.2MM	
APP:	DATE:	PART NO:
CHK:	DATE:	DESCRIPTION:
DWN:	DATE: 2021-10-11	Version: B01