

5.0" WVGA
High brightness color TFT-LCD module

Model: VM05B1 VC

Date: May. 09th, 2022

**Note: This specification is subject to change
without notice**

Customer : _____

Date : _____

Approved

Prepared

Date:

Date:

Contents

- 1. Handling Precautions**
- 2. General Description**
 - 2.1 Overview
 - 2.2 Features
 - 2.3 Application
 - 2.4 Display specifications
 - 2.5 Optical characteristics
- 3. Absolute Maximum Ratings**
- 4. Electrical characteristics**
 - 4.1 LCD electronics specification
 - 4.2 Backlight unit
 - 4.3 Interface connector
 - 4.3.1 TFT connector(CN1)
- 5. Signal characteristics**
 - 5.1 Timing characteristics
 - 5.1.1 AC timing characteristics
 - 5.1.2 RGB interface
- 6. Shipping package**
- 7. Mechanical Characteristics**

RECORD OF REVISION

Version and Date	Page	Old description	New description	Remark
0.1 2022/05/09	All	First Edition for customer		

1. Handling Precautions

- 1) Since front polarizer is easily damaged, pay attention not to scratch it.
- 2) Be sure to turn off power supply when inserting or disconnecting from input connector.
- 3) Wipe off water drop immediately. Long contact with water may cause discoloration or spots.
- 4) When the panel surface is soiled, wipe it with absorbent cotton or other soft cloth.
- 5) Since the panel is made of glass, it may break or crack if dropped or bumped on hard surface.
- 6) Since CMOS LSI is used in this module, take care of static electricity and insure human earth when handling.
- 7) Do not open or modify the Module Assembly.
- 8) Do not press the reflector sheet at the back of the module to any directions.
- 9) At the insertion or removal of the Signal Interface Connector, be sure not to rotate nor tilt the Interface Connector of the TFT Module.
- 10) After installation of the TFT Module into an enclosure, do not twist nor bend the TFT Module even momentary. At designing the enclosure, it should be taken into consideration that no bending/twisting forces are applied to the TFT Module from outside. Otherwise the TFT Module may be damaged.

2. General Description

2.1 Overview

This specification applies to the Color Active Matrix Liquid Crystal Display composed of a TFT-LCD display a LED backlight system. The screen format is intended to support WVGA (800(H) x 480(V)) screen and 16.7M colors.

2.2 Features

- High brightness display, 1000nits by LED backlight.
- Long operation lifetime BLU design
- RoHS Compliance
- Wide operation temperature
- Wide view angle, IPS TFT

2.3 Application

Industrial applications.

2.4 Display specifications

Items	Unit	Specification
Screen Diagonal	inch	5.0"
Active Area	mm	108.0 (H) X 64.8 (V)
Pixels H x V	pixels	800 x3(RGB) x 480
Pixels Pitch	um	135 (per one triad) x 135
Pixel Arrangement		RGB Vertical stripe
Display mode		Normally black, IPS
White luminance (center)	Cd/m ²	1000 (Typ)
Contrast ratio		1000:1 (Typ.)
Optical Response Time	msec	30 ms (Typ. On/off)
Normal Input Voltage VDD	Volt	3.3
Power Consumption (Vcc Line + LED backlight)	Watt	TBD W (VDD line=TBD W; LED lines= 1.92 W)
Weight	Grams	TBD
Physical size	mm	120.7 (W)×75.8 (H)×2.8 (D)
Electrical Interface		24-bit parallel RGB interface
Support colors		16.7M colors
Surface Treatment		Anti-glare and hard-coating 3H
Temperature range		
Operating	°C	-30 ~ 85 (TFT surface)
Storage	°C	-30 ~ 85
RoHS Compliance		RoHS Compliance

2.5 Optical characteristics

The following optical characteristics are measured under stable condition at 25 °C

Items	Unit	Conditions	Min.	Typ.	Max.	Note
Viewing angle	Deg.	Horizontal (Right)		80		2
		CR=10 (Left)		80		
		Vertical (Up)		80		
		CR=10 (Down)		80		
Contrast Ratio		Normal Direction	800	1000		3
Response Time	msec	Raising + Falling		30	40	4
Color / Chromaticity Coordinates (CIE)		Red x	-0.05	0.573	+0.05	5
		Red y		0.353		
		Green x		0.368		
		Green y		0.576		
		Blue x		0.138		
		Blue y		0.094		
		White x		0.310		
		White y		0.339		
Color coordinates (CIE) White						
Center Luminance	Cd/m ²		800	1000		6
Luminance Uniformity	%		70	75		7
Crosstalk (in 60 Hz)	%				1.5	
Flicker	dB				-20	

Note 1: Measurement method

The LCD module should be stabilized at given temperature for 0.5 hour to avoid abrupt temperature change during measuring. In order to stabilize the luminance, the measurement should be executed after lighting Backlight for 1 hour in a windless room.

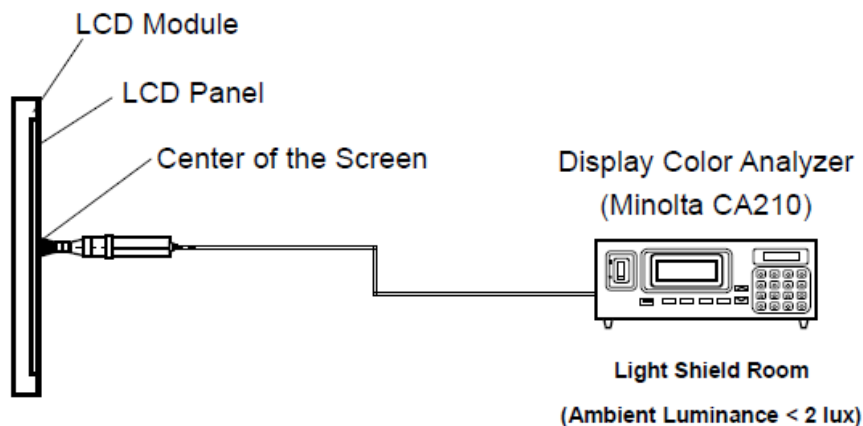

Note 2: Definition of viewing angle

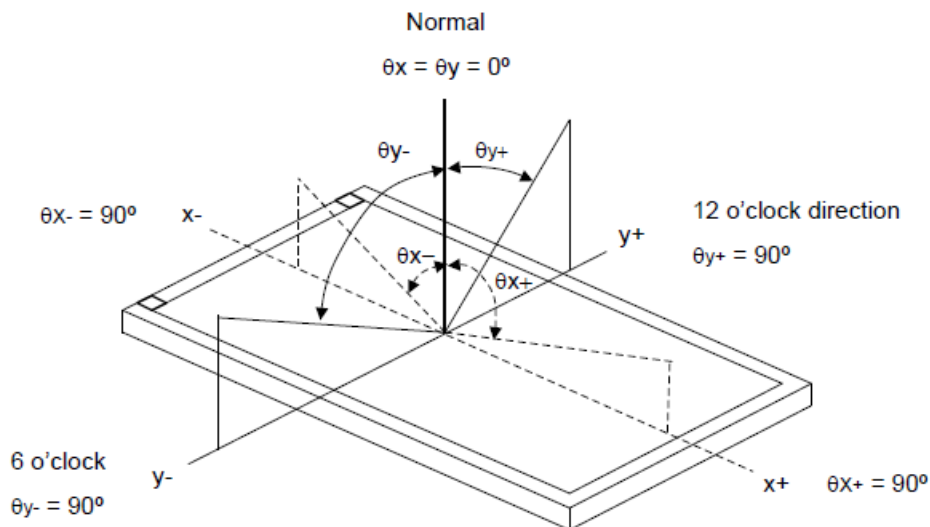

Note 3: Contrast ratio is measured by Minolta CA210

Note 4: Definition of Response time

The output signals of photo detector are measured when the input signals are changed from “Full Black” to “Full White” (rising time), and from “Full White” to “Full Black” (falling time), respectively. The response time is interval between the 10% and 90% of amplitudes. Please refer to the figure as below.

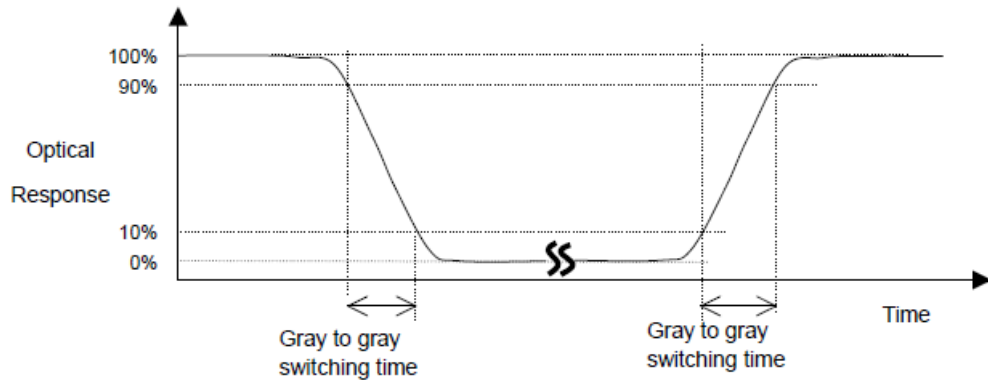

Note 5: Color chromaticity and coordinates (CIE) is measured by Minolta CA210

Note 6: Center luminance is measured by Minolta CA210

Note 7: Luminance uniformity of these 5 points is defined as below and measured by Minolta CA210



$$\text{Uniformity} = (\text{Min. Luminance of 5 points}) / (\text{Max. Luminance of 5 points})$$

3. Absolute Maximum Ratings

Absolute maximum ratings of the module are as following:

Item	Symbol	Min.	Max.	Unit
Power supply	VDD	-0.3	4.0	V
Input Voltage	V _{in}	-0.3	VDD +0.3	V
Operating Temperature	TOP	-30	85	°C
Storage Temperature	TST	-30	85	°C

4. Electrical characteristics

4.1 LCD electronics specification

Item	Symbol	Min.	Typ.	Max.	Unit	Remark
Power supply	VDD	3.0	3.3	3.6	V	-
Power Supply Current	IVDD	-	75	150	ma	-
Input High Voltage	VIH	0.7VDD	-	VDD	V	-
Input Low Voltage	VIL	GND	-	0.3VDD	V	-
Output High Voltage	VOH	VDD-0.4	-	VDD	V	-
Output Low Voltage	VOL	GND	-	GND+0.4	V	-
I/O Lear Current	ILI	-1	-	1	uA	-

4.2 Backlight unit

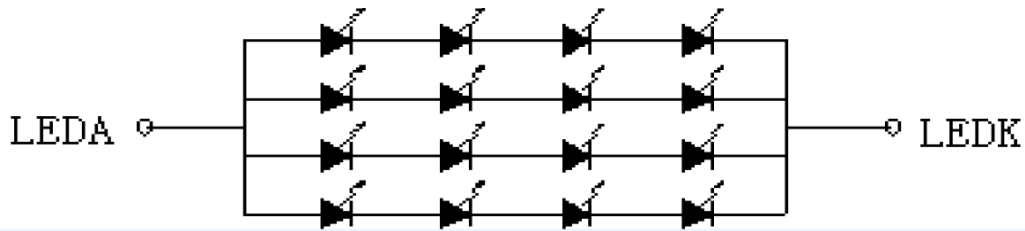

Parameter	Min	Typ	Max	Unit	Note
LED voltage (VL)	22	24	26	[V]	2
LED current (IL)		80		[mA]	2
LED power (PL)		1.92		[W]	
LED lite time (MTBF)		20,000		[Hour]	1

Note 1: The LED Supply Voltage is defined by the number of LED at $T_a=25^{\circ}\text{C}$ and $I_f=80\text{mA}$.

Note 2: LED current is measured by utilizing a high frequency current meter as shown below:

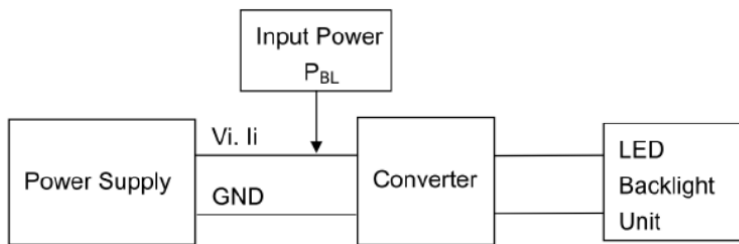

Note 3: The “LED life time” is defined as the module brightness decrease to 50% original brightness at $T_a=25^{\circ}\text{C}$ and $I_f=80\text{mA}$. The LED lifetime could be decreased if operating I_f is larger than 80mA.

Note 4: LED light bar circuit:

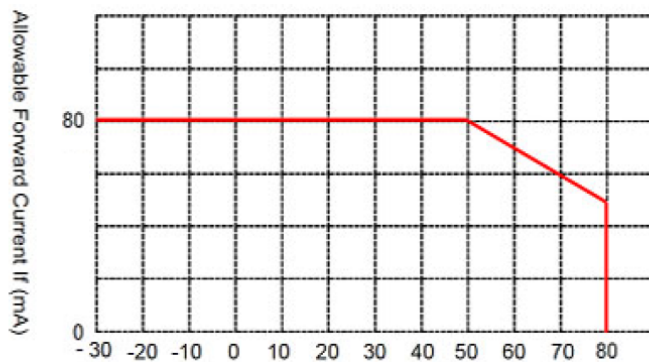

4.3 Interface connector

4.3.1 TFT connector(CN1)

PIN NO.	PIN NAME	DESCRIPTION
1	VLED-	LED backlight (Cathode).
2	VLED+	LED backlight (Anode).
3	GND	Ground.
4	VDD	Power supply
5~12	R0~R7	Red Data
13~20	G0~G7	Green Data
21~28	B0~B7	Blue Data
29	GND	Ground.
30	PCLK	Clock
31	DISP	Display on/off
32	HSYNC	Horizontal sync input in RGB mode.
33	VSYNC	Vertical sync input in RGB mode.
34	DE	Data enable input. Active high to enable the input data bus.
35	NC	NC
36	GND	Ground.
37	NC	NC
38	NC	NC
39	NC	NC
40	NC	NC

5. Signal characteristics

5.1 Timing characteristics

5.1.1 AC timing characteristics

System Bus Timing for RGB Interface

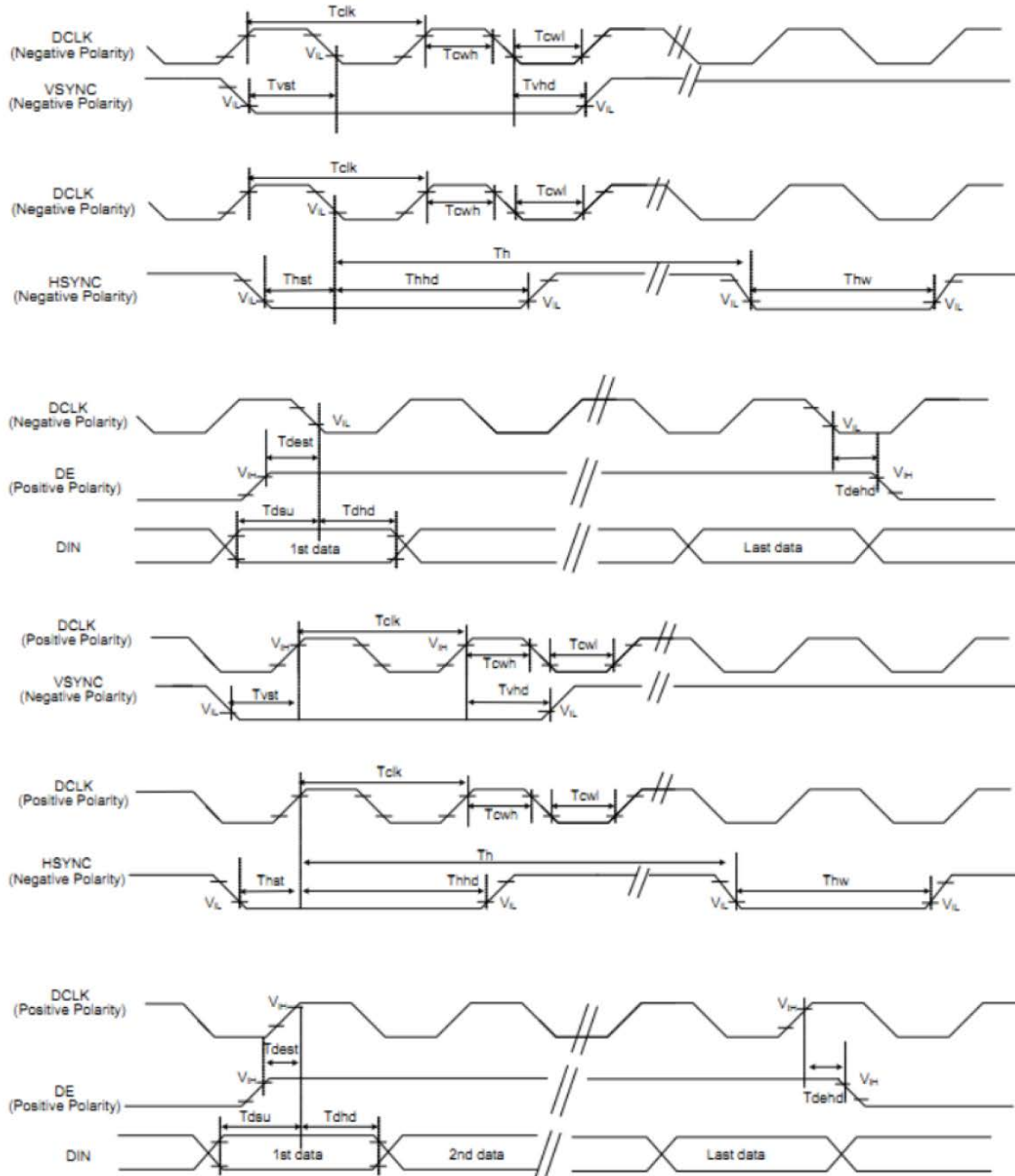

Item	Symbol	Min.	Typ.	Max.	Unit	Conditions
CLK Pulse Duty	Tcw	40	50	60	%	
HSYNC Width	Thw	2	-	-	DCLK	
HSYNC Period	Th	55	60	65	us	
VSYNC Setup Time	Tvst	12	-	-	ns	
VSYNC Hold Time	Tvhd	12	-	-	ns	
HSYNC Setup Time	Thst	12	-	-	ns	
HSYNC Hold Time	Thhd	12	-	-	ns	
Data Setup Time	Tdsu	12	-	-	ns	
Data Hold Time	Tdhd	12	-	-	ns	
DE Setup Time	Tdest	12	-	-	ns	
DE Hold Time	Tdehd	12	-	-	ns	

5.1.2 RGB interface

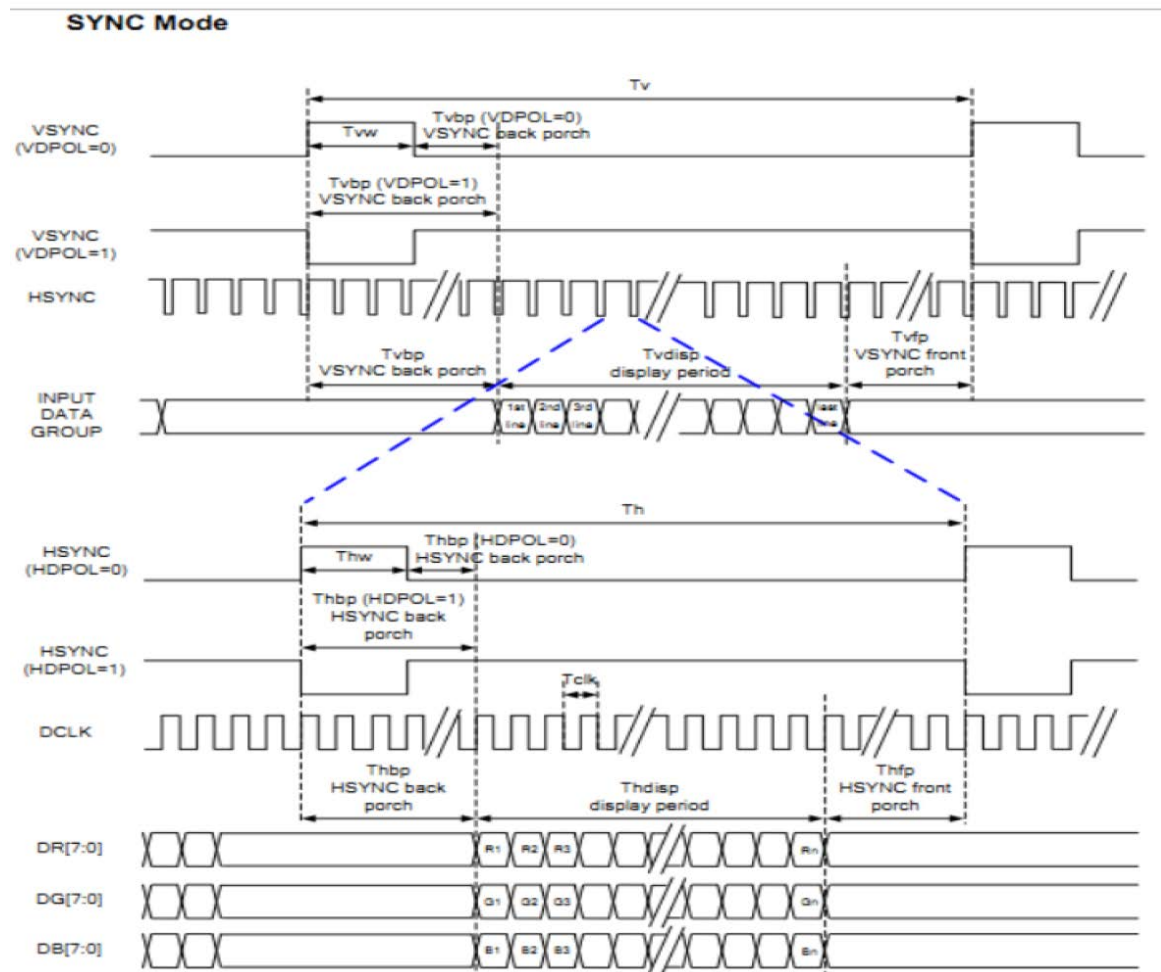

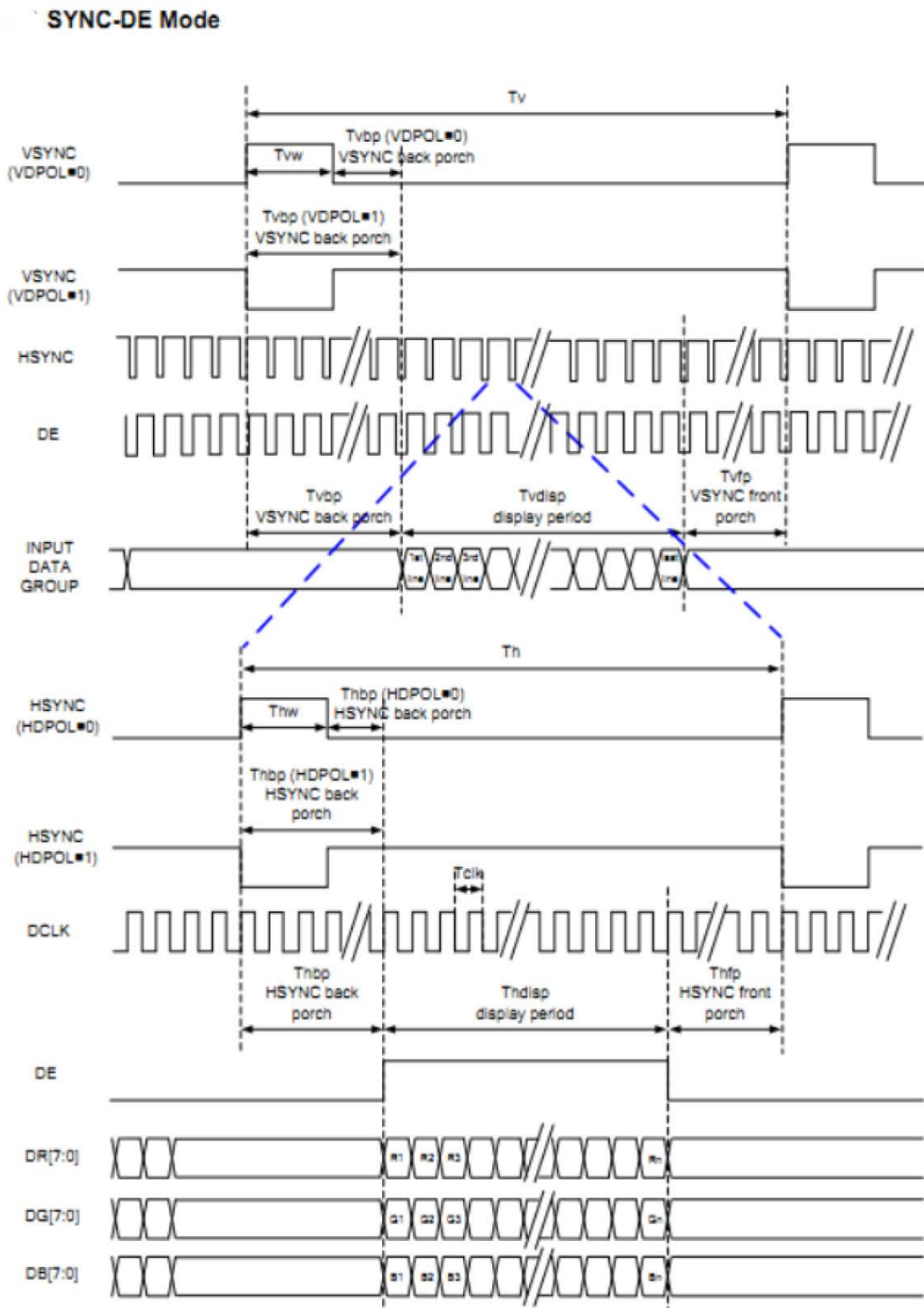

DE Mode

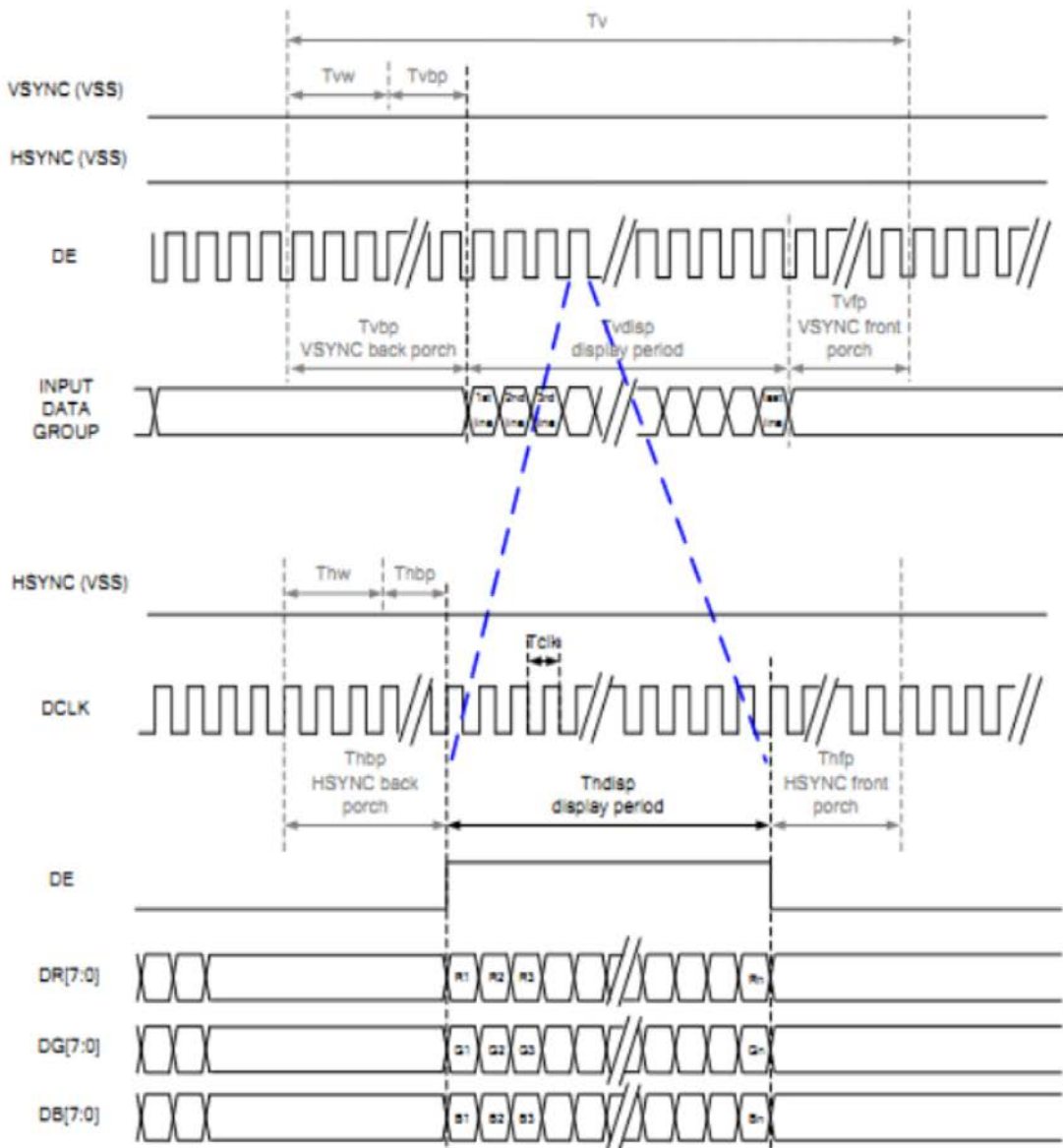

RGB Mode Selection Table	DCLK	HSYNC	VSYNC	DE
SYNC - DE Mode	Input	Input	Input	Input
SYNC Mode	Input	Input	Input	GND
DE Mode	Input	GND	GND	Input

Parallel 24-bit RGB Interface Timing Table							
Item	Symbol	Min.	Typ.	Max.	Unit	Remark	
DCLK Frequency		Fclk	23	25	27	MHz	
HSYNC	Period Time	Th	808	816	896	DCLK	
	Display Period	Thdisp	800			DCLK	
	Back Porch	Thbp	4	8	48	DCLK	
	Front Porch	Thfp	4	8	48	DCLK	
	Pulse Width	Thw	2	4	8	DCLK	
VSYNC	Period Time	Tv	488	496	504	HSYNC	
	Display Period	Tvdisp	480			HSYNC	
	Back Porch	Tvbp	4	8	12	HSYNC	
	Front Porch	Tvfp	4	8	12	HSYNC	
	Pulse Width	Tvw	2	4	8	HSYNC	

6. Reliability Test

Environment test conditions are listed as following table.

Items	Required Condition	Note
Temperature Humidity Bias (THB)	Ta=50°C, 85%RH, 96hours	
High Temperature Operation (HTO)	Ta= 85°C, 96hours	
Low Temperature Operation (LTO)	Ta= -30°C, 96hours	
High Temperature Storage (HTS)	Ta= 85°C, 96hours	
Low Temperature Storage (LTS)	Ta= -30°C, 96hours	
Thermal Shock Test (TST) (Storage)	<p style="text-align: center;"> -20°C \longleftrightarrow 25°C \longleftrightarrow 70°C (30min) \longleftarrow (5min) \longrightarrow (30min) 1cycle Total 10cycle </p>	
ESD (Electrostatic Discharge)	Voltage: $\pm 8KV$, R:330 Ω , C:150PF, Air Mode, 10times	
Vibration Test	Frequency:10Hz~55Hz~10Hz Amplitude:1.5mm X, Y, Z direction for total 3hours (Packing condition test will be tested by a carton)	
Dropping Test	Drop to the ground from 1M height one time every side of carton. (Packing condition test will be tested by a carton)	

Note 1: Inspection after 2~4hours storage at room temperature, the samples should be free from defects:

- 1, Air bubble in the LCD.
- 2, Seal leak.
- 3, Non-display.
- 4, Missing segments.
- 5, Glass crack.
- 6, Current IDD is twice higher than initial value.
- 7, The surface shall be free from damage.
- 8, The electric characteristic requirements shall be satisfied.

REMARK:

- 1, The Test samples should be applied to only one test item.
- 2, Sample side for each test item is 5~10pcs.
- 3, For Damp Proof Test, Pure water(Resistance > 10M Ω) should be used.

4, In case of malfunction defect caused by ESD damage, if it would be recovered to normal state after resetting, it would be judge as a good part.

5, The evaluation should be accepted from reliability test with humidity and temperature: Some defects such as black spot/blemish can happen by natural chemical reaction with humidity and Fluorescence has.

6, Failure Judgment Criterion: Basic Specification Electrical Characteristic, Mechanical Characteristic, Optical Characteristic.

**7. Shipping package
(TBD)**

8. Mechanical Characteristics

