

**6.5" VGA**

**High brightness color TFT-LCD module**

**Model control code: VM06B4 V1**

**Date: Mar. 28<sup>th</sup>, 2022**

**Version: 01**

**Note: This specification is subject to change  
without notice**

<b>Customer :</b> _____
<b>Date :</b> _____

<b>Approved</b>	<b>Prepared</b>
<b>Date:</b>	<b>Date:</b>

--

## Contents

- 1. Handling Precautions**
- 2. General Description**
- 3. Functional Block Diagram**
- 4. Absolute Maximum Ratings**
  - 4.1 Absolute Ratings of TFT LCD Module
  - 4.2 Absolute Ratings of Backlight Unit
  - 4.3 Absolute Ratings of Environment
- 5. Electrical characteristics**
  - 5.1 TFT LCD Module
  - 5.2 Backlight Unit
- 6. Signal Characteristic**
  - 6.1 Pixel Format Image
  - 6.2 The Input Data Format
  - 6.4 Interface Timing
  - 6.5 Power ON/OFF Sequence
- 7. Connector & Pin Assignment**
  - 7.1 TFT LCD Module
  - 7.2 Backlight Unit
- 8. Reliability Test**
- 9. Shipping Label**
- 10. Mechanical Characteristic**

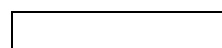

RECORD OF REVISION

Version and Date	Page	Old description	New description	Remark
0.1 2011/10/20	All	First Edition for customer		
0.2 2014/12/30	All		Brightness: 1600 nits BLU power: 4.84W	
0.3 2019/01/14	6	Total power : 5.7W	Total power : 3.56W	
	14	LED power : 4.84 LED voltage : 37.2 LED current : 130mA MTBF : 50,000hr	LED power : 2.7W LED voltage : 27V LED current : 100mA MTBF : 100,000hr	
0.4 2022/03/28	All		TFT and IC changed	

**1. HANDLING PRECAUTIONS**

- 1) Since front polarizer is easily damaged, pay attention not to scratch it.
- 2) Be sure to turn off power supply when inserting or disconnecting from input connector.
- 3) Wipe off water drop immediately. Long contact with water may cause discoloration or spots.
- 4) When the panel surface is soiled, wipe it with absorbent cotton or other soft cloth.
- 5) Since the panel is made of glass, it may break or crack if dropped or bumped on hard surface.
- 6) Since CMOS LSI is used in this module, take care of static electricity and insure human earth when handling.
- 7) Do not open or modify the Module Assembly.
- 8) Do not press the reflector sheet at the back of the module to any directions.
- 9) In case if a Module has to be put back into the packing container slot after once it was taken out from the container, do not press the center of display.
- 10) At the insertion or removal of the Signal Interface Connector, be sure not to rotate nor tilt the Interface Connector of the TFT Module.
- 11) After installation of the TFT Module into an enclosure, do not twist nor bend the TFT Module even momentary. At designing the enclosure, it should be taken into consideration that no bending/twisting forces are applied to the TFT Module from outside. Otherwise the TFT Module may be damaged.

## 2. General Description

### 2.1, Overview

VM06B4 V1 is a Color Active Matrix Liquid Crystal Display composed of a TFT-LCD display, a driver circuit, and a backlight system. The screen format is intended to support VGA(640(H) x 480(V)) screen and 16.7M (RGB 8-bits) or 262k colors (RGB 6-bits). All input signals are LVDS interface compatible.

### 2.2 Features

- Sunlight readable display, 1600nits.
- LED backlight with extra-long life design
- Extra wide operation temperature
- RoHS Compliance

### 2.3 Application

Industrial Application.

## 2.4 Display Specifications

Items	Unit	Specification
Screen Diagonal	inch	6.5
Active Area	mm	132.48 (H) x 99.36 (V)
Pixels H x V	pixels	640x3(RGB) x 480
Pixels Pitch	um	207 (per one triad) x 207
Pixel Arrangement		RGB Vertical stripe
Display mode		AHVA, Normally black
White luminance (center)	Cd/m <sup>2</sup>	1600 (Typ.)
Contrast ratio		1000 (Typ.)
Optical Response Time	msec	25 ms (Typ. on/off)
Normal Input Voltage VDD	Volt	3.3
Power Consumption (VDD Line + LED Lines)	Watt	3.1W (VDD=0.4W; LED=2.7W)
Weight	Grams	170 typ.
Physical size	mm	153.0(H)x 118.0 (V) x 10.9 (D) (typ.)
Electrical Interface		1 Chanel LVDS
Support Colors		16.7 M / 262k
Surface Treatment		Glare, AR, 3H
Temperature range		
Operating	°C	-30 ~ 80 (TFT surface temperature)
Storage (Shipping)	°C	-30 ~ 80
RoHS Compliance		RoHS Compliance

2.5 Optical Characteristics

The following optical characteristics are measured under stable condition at 25 °C

Items	Unit	Conditions	Min.	Typ.	Max.	Note
Viewing angle	Deg.	Horizontal (Right)	80	89		2
		CR=10 (Left)	80	89		
		Vertical (Up)	80	89		
		CR=10 (Down)	80	89		
Contrast Ratio		Normal Direction	700	1000		3
Response Time	msec	Raising time (T <sub>rR</sub> )		15		4
		Falling time (T <sub>rF</sub> )		10		
		Raising + Falling		25		
Color / Chromaticity Coordinates (CIE)		Red x	-0.05	0.604	+0.05	5
		Red y		0.358		
		Green x		0.336		
		Green y		0.598		
		Blue x		0.151		
		Blue y		0.115		
Color coordinates (CIE) White		White x		0.313		
		White y		0.329		
Center Luminance	Cd/m <sup>2</sup>		1300	1600		6
Luminance Uniformity	%			70		7
Crosstalk (in 60 Hz)	%				1.2	
Flicker	dB				-20	
Color Gamut	%		50	55		

Note 1: Measurement method

The LCD module should be stabilized at given temperature for 0.5 hour to avoid abrupt temperature change during measuring. In order to stabilize the luminance, the measurement should be executed after lighting Backlight for 1 hour in a windless room.

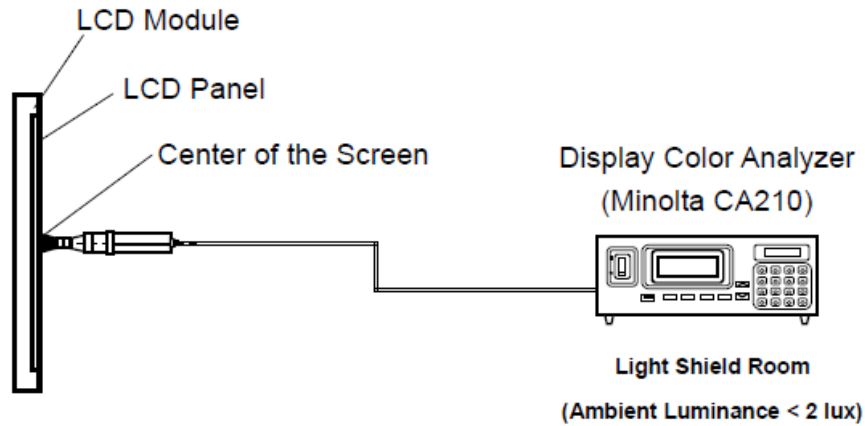

Note 2: Definition of viewing angle

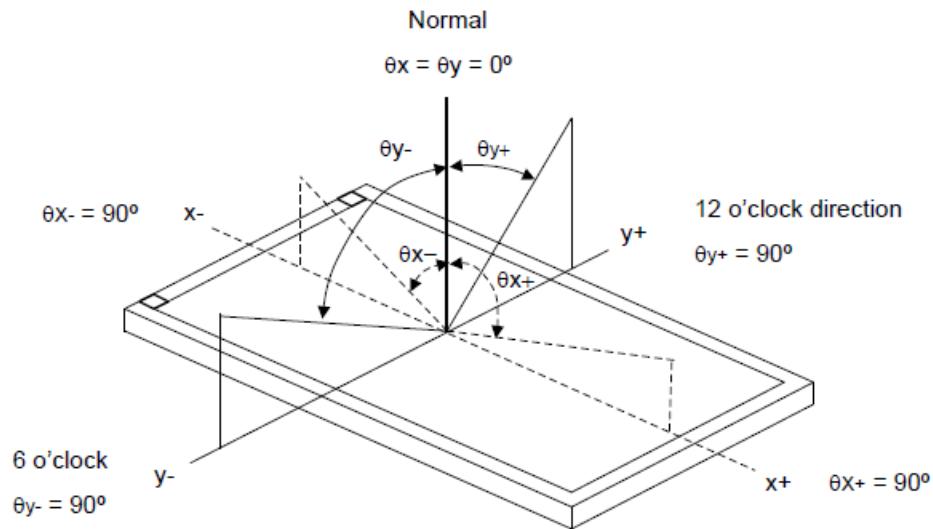

Note 3: Contrast ratio is measured by Minolta CA210



Note 4: Definition of Response time

The output signals of photo detector are measured when the input signals are changed from “Full Black” to “Full White” (rising time), and from “Full White” to “Full Black” (falling time), respectively. The response time is interval between the 10% and 90% of amplitudes. Please refer to the figure as below.

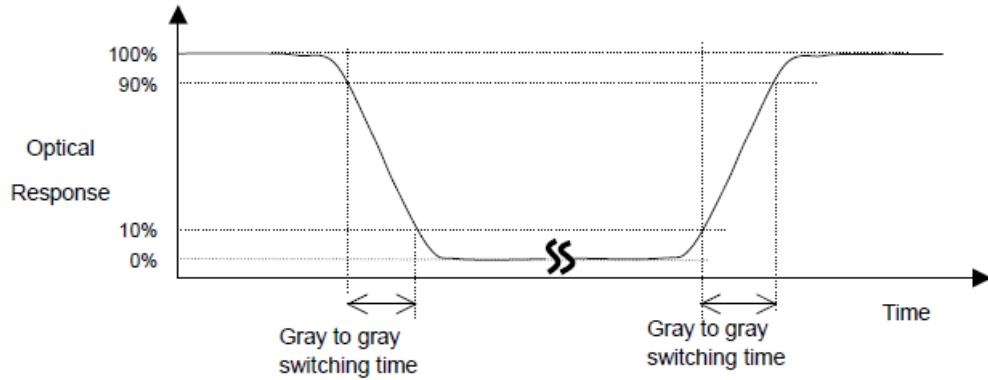

Note 5: Color chromaticity and coordinates (CIE) is measured by Minolta CA210

Note 6: Center luminance is measured by Minolta CA210

Note 7: Luminance uniformity of these 5 points is defined as below and measured by Minolta CA210

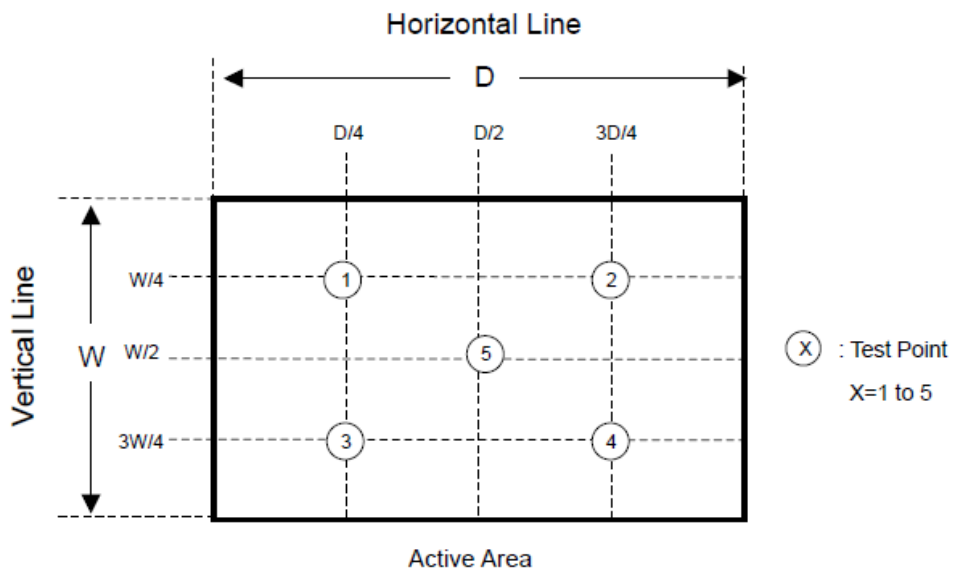

$$\text{Uniformity} = (\text{Min. Luminance of 5 points}) / (\text{Max. Luminance of 5 points})$$

**3. Functional Block Diagram**

The following diagram shows the functional block of the 6.5 inches Color TFT-LCD Module:

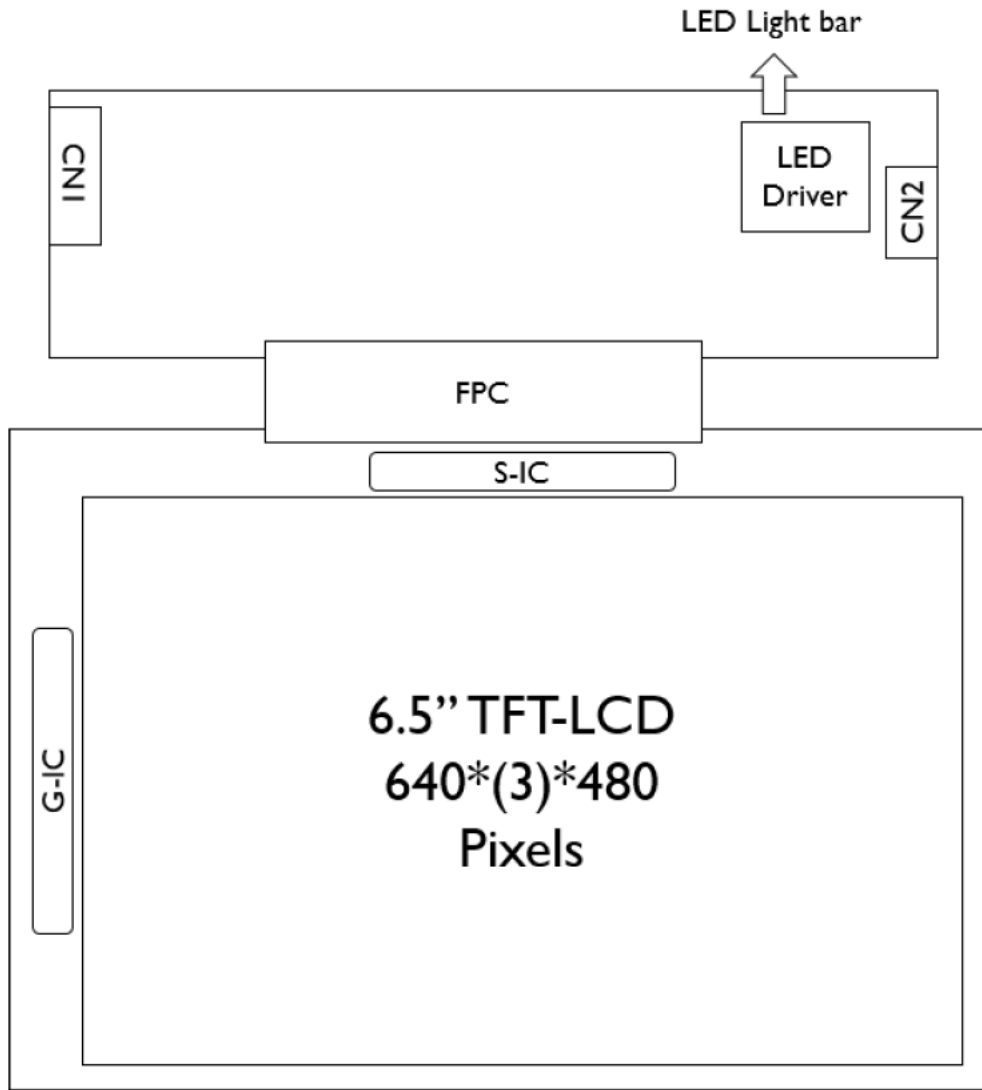

**4. Absolute Maximum Ratings**

Absolute maximum ratings of the module are as following:

4.1 TFT LCD Module

Items	Symbol	Min	Max	Unit	Conditions
Logic/ LCD drive voltage	VDD	-0.3	4.0	Volt	Note 1, 2
LCD Input Signal Voltage	VIN	-0.3	4.0	Volt	

4.2 Backlight unit

Items	Symbol	Min	Max	Unit	Conditions
LED Current	I LED		240	mA	Note 1, 2

4.3 Absolute Ratings of Environment

Items	Symbol	Values			Unit	Conditions
		Min.	Typ.	Max.		
Operation temperature	T <sub>OP</sub>	-30	-	80	°C	Note 3
Operation Humidity	H <sub>OP</sub>	8		90	%	
Storage temperature	T <sub>ST</sub>	-30		80	°C	
Storage Humidity	H <sub>ST</sub>	8		90	%	

Note 1: With in Ta= 25°C

Note 2: Permanent damage to the device may occur if exceed maximum values

Note 3: For quality performance, please refer to IIS (Incoming Inspection Standard).

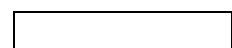

**5. Electrical characteristics**

5.1 TFT LCD Module

5.1.1 Power Specification

Symbol	Parameter	Min	Typ	Max	Units	
VDD	Logic/LCD Drive Voltage	3.0	3.3	3.6	Volt	
IDD	VDD Current	-	(120)	(133)	mA	All White Pattern (VDD=3.3V, at 60Hz)
Irush	LCD Inrush Current	-	-	1.0	A	Note 1
PDD	VDD Power	-	(0.4)		Watt	All White Pattern (VDD=3.3V, at 60Hz)
VDDrp	Allowable Logic/LCD Drive Ripple Voltage	-	-	100	mVp-p	All White Pattern (VDD=3.3V, at 60Hz)

Note 1: Measurement condition:

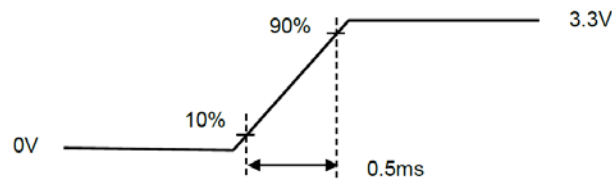
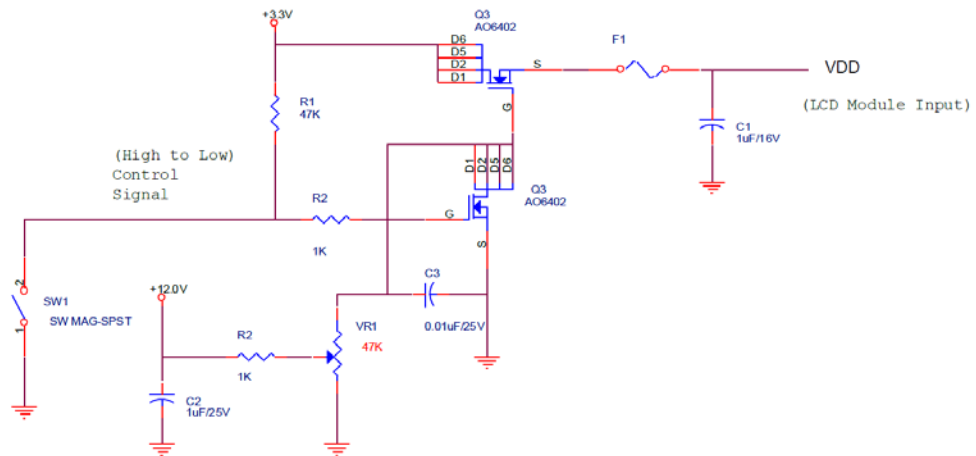

VDD rising time

5.1.2 Signal Electrical Characteristics

Input signals shall be low or Hi-Z state when VDD is off.

LVDS signal (Note 1)

Parameter	Symbol	Min.	Typ.	Max.	Unit	Remark
Differential Input High Threshold	VTH	-	-	100	mV	VCM=1.20V
Differential Input Low Threshold	VTL	-100	-	-	mV	VCM=1.20V
Input Differential Voltage	VID	200	400	600	mV	
Differential Input Common Mode Voltage	VCM	1.1	-	1.45	V	VTH, VTL= ±100mV

LVDS Transmitter: THC63LVDM83A (THINE) or equivalent

Note 1: LVDS Signal Waveform.

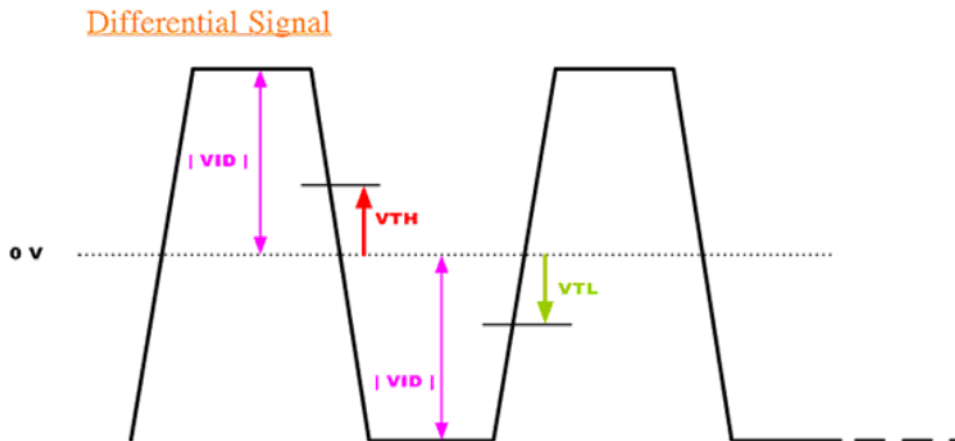
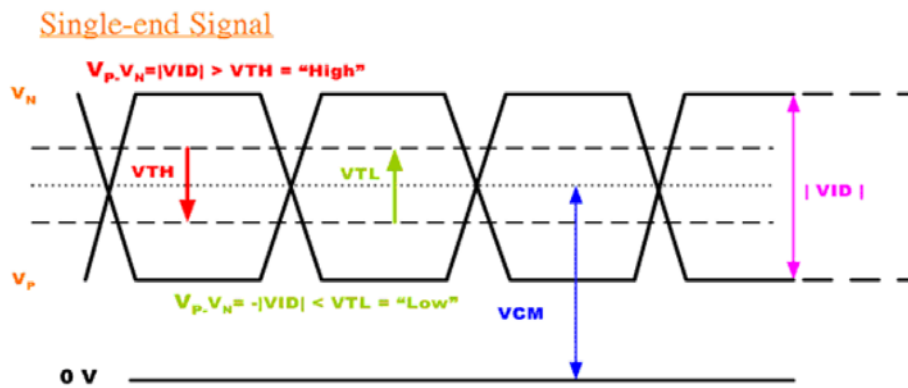

## 5.2 Backlight Unit

Parameter guideline is under stable conditions at 25°C (Room Temperature):

Parameter	Min	Typ	Max	Unit	Note
LED voltage (VL)		27		[V]	2
LED current (IL)		100		[mA]	2,
LED power (PL)		2.7		W	
LED Life Time(LTLED)		100,000		[Hour]	1

Note 1: The “LED lift time” is defined as the module brightness decrease to 50% original brightness that the ambient temperature is 25°C and typical LED Current at 100 mA (Long lifetime mode).

**6. Signal Characteristic**

6.1 Pixel Format Image

Following figure shows the relationship of the input signals and LCD pixel format.

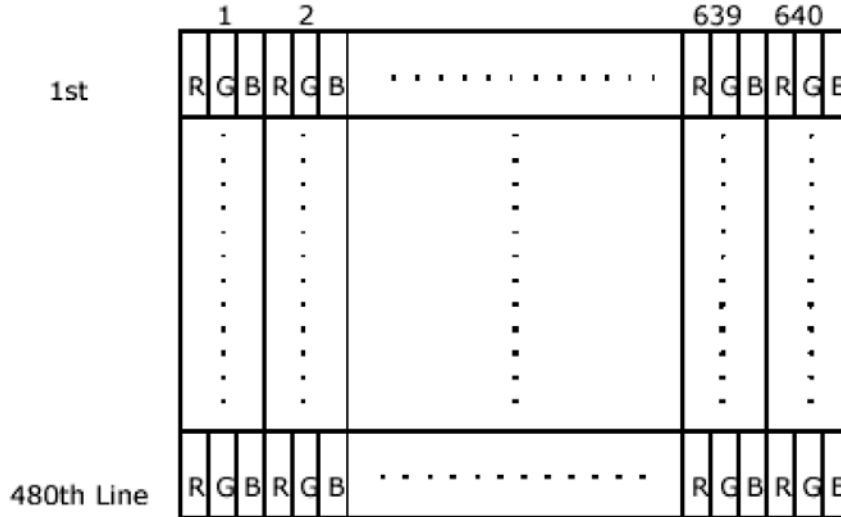

6.2 Scanning Direction

The following figures show the image seen from the front view. The arrow indicates the direction of scan.



R/L=Low or NC, U/D=Low or NC

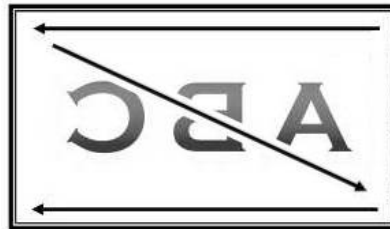

R/L=High, U/D=Low or NC

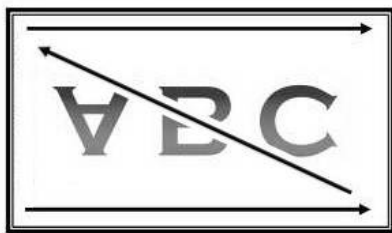

R/L=Low or NC, U/D=High

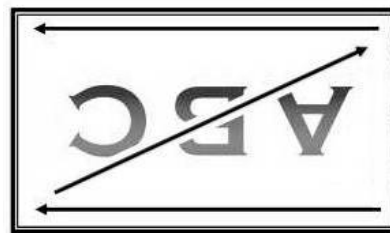

R/L=High, U/D=High

Note 1: TFT-LCD interface signal description is shown in section 6.4.

6.3 The Input Data Format

SEL68 = "Low" or "NC" for 6 bits LVDS Input

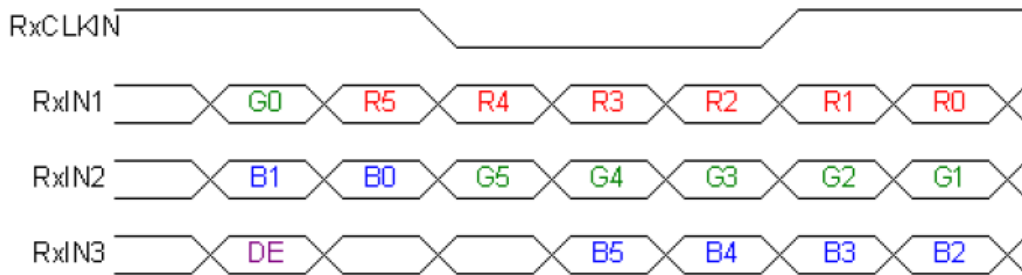

SEL68 = "High" for 8 bits LVDS Input

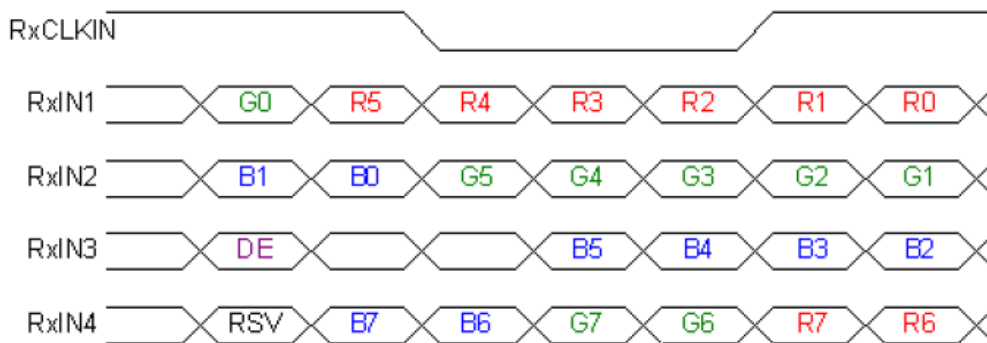

Signal Name	Description	Remark
R7	Red Data 7	Red-pixel Data
R6	Red Data 6	
R5	Red Data 5	
R4	Red Data 4	
R3	Red Data 3	
R2	Red Data 2	
R1	Red Data 1	
R0	Red Data 0	
G7	Green Data 7	Green-pixel Data
G6	Green Data 6	
G5	Green Data 5	
G4	Green Data 4	
G3	Green Data 3	
G2	Green Data 2	
G1	Green Data 1	
G0	Green Data 0	
B7	Blue Data 7	Blue-pixel Data
B6	Blue Data 6	
B5	Blue Data 5	
B4	Blue Data 4	
B3	Blue Data 3	
B2	Blue Data 2	
B1	Blue Data 1	
B0	Blue Data 0	
RxCLKIN	LVDS Data Clock	
DE	Data Enable Signal	When the signal is high, the pixel data shall be valid to be displayed.
RSV	Reserved Signal	"High" or "Low" is acceptable

Note 1: Output signals from any system shall be low or Hi-Z state when VDD is off.



6.4 TFT- LCD Interface Signal Description

LVDS is a differential signal technology for high-speed data transfer LCD interface. LVDS Transmitter shall be THC63LVDM83A (THINE) or equivalent.

Pin No.	Symbol	Pin Description
1	VDD	Power supply, 3.3V (typical)
2	VDD	Power supply, 3.3V (typical)
3	GND	Ground
4	SEL68	Selection for either 6bit or 8bit LVDS input: SEL68 = "Low" or "NC", accepts 6bit LVDS data input; SEL68 = "High", accepts 8bit LVDS data input.
5	RxIN0-	Negative LVDS differential input(R0-R5, G0)
6	RxIN0+	Positive LVDS differential input(R0-R5, G0)
7	GND	Ground
8	RxIN1-	Negative LVDS differential input(G1-G5, B0-B1)
9	RxIN1+	Positive LVDS differential input(G1-G5, B0-B1)
10	GND	Ground
11	RxIN2-	Negative LVDS differential input(B2-B5, Hsync, Vsync, DE)
12	RxIN2+	Positive LVDS differential input(B2-B5, Hsync, Vsync, DE)
13	GND	Ground
14	RxCLKIN-	Negative LVDS differential clock input
15	RxCLKIN+	Positive LVDS differential clock input
16	NC	No connection
17	U/D	Vertical Reverse ("L" or Open: Normal, "H": Reverse)
18	R/L	Horizontal Reverse ("L" or Open: Normal, "H": Reverse)
19	RxIN3-	Negative LVDS differential input (R6-R7, G6-G7, B6-B7) NC for 6bit LVDS input.
20	RxIN3+	Positive LVDS differential input (R6-R7, G6-G7, B6-B7) NC for 6bit LVDS input.

Note 1: "Low" stands for 0V. "High" stands for 3.3V. "NC" stands for "No Connection".

Note 2:

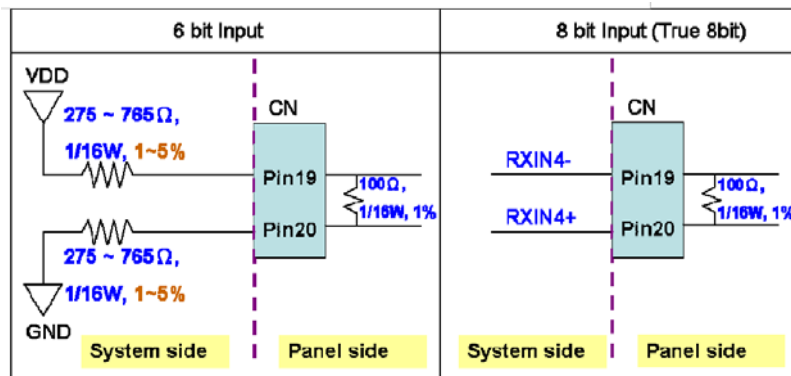

6.5 Interface Timing

6.5.1 Timing Characteristics

DE mode only

Signal		Symbol	Min.	Typ.	Max.	Unit	Remark
Clock frequency (DOTCLK)		$1/T_{\text{CLOCK}}$	20	25.2	50	MHz	Note1
Horizontal Section	Period	$T_{\text{H}}$	770	800	1070	$T_{\text{CLOCK}}$	Note1
	Active	$T_{\text{HD}}$	640				
	Blanking	$T_{\text{HB}}$	130	160	430		
Vertical Section	Period	$T_{\text{V}}$	520	525	622	$T_{\text{LINE}}$	Note1
	Active	$T_{\text{VD}}$	480				
	Blanking	$T_{\text{VB}}$	40	45	142		

Note 1: Recommended frame rate is 60 Hz.

6.5.2 Input Timing Diagram

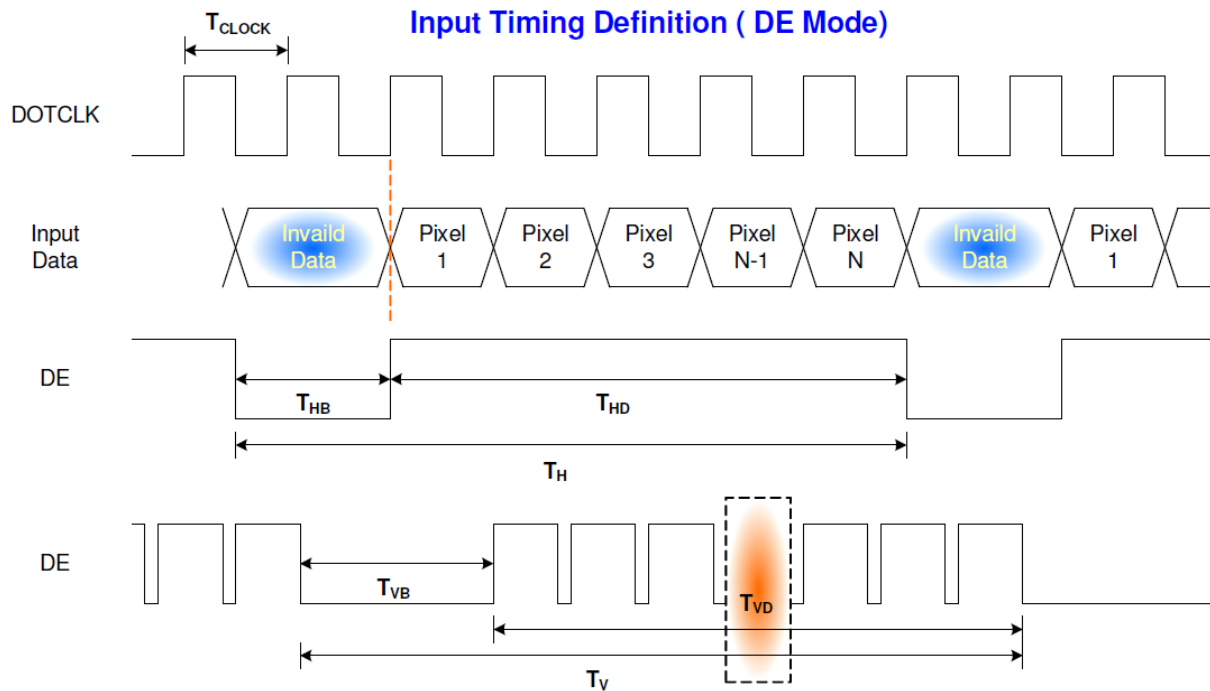

6.6 Power ON/OFF Sequence

VDD power and lamp on/off sequence is as below. Interface signals are also shown in the chart. Signals from any system shall be Hi-Z state or low level when VDD is off.

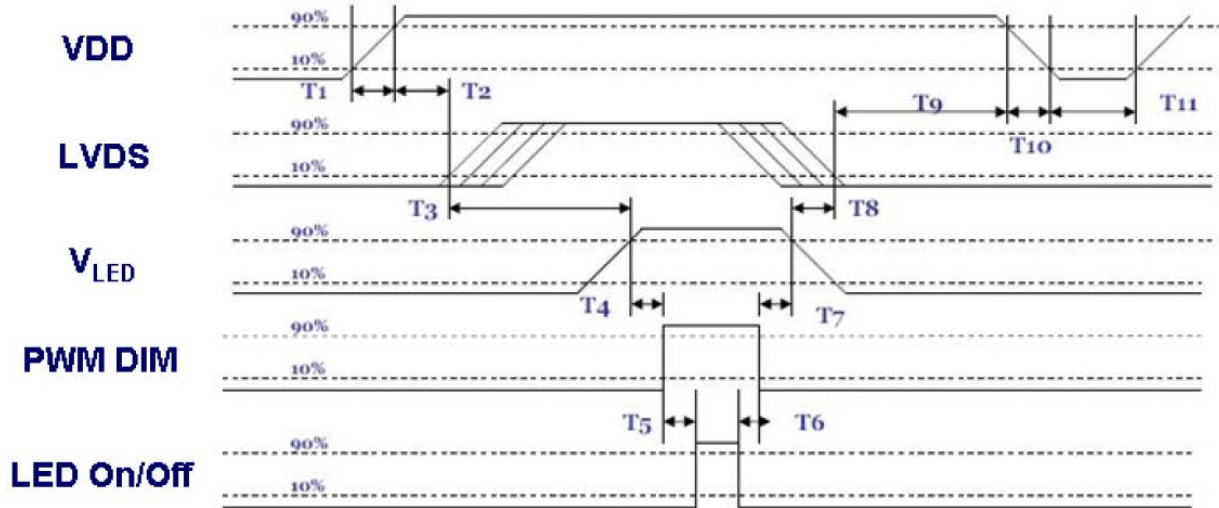

Power ON/OFF sequence timing

Parameter	Value			Units
	Min.	Typ.	Max.	
T1	0.5	-	3	ms
T2	30	40	50	ms
T3	200	-	-	ms
T4	10	-	-	ms
T5	10	-	-	ms
T6	0	-	-	ms
T7	10	-	-	ms
T8	100	-	-	ms
T9	0	16	50	ms
T10	-	-	10	ms
T11	1000	-	-	ms

ON/OFF sequence should be applied to avoid abnormal function in the display. Please make sure to turn off the power when you plug the cable into the input connector or pull the cable out of the connector.

### 7.0 Connector & Pin Assignment

Physical interface is described as for the connector on module. These connectors are capable of accommodating the following signals and will be following components.

#### 7.1 TFT LCD Module(CN1)

Manufacturer	STM
Connector Model Number	MSB24013P20, compatible with I-PEX 20268-020E
Mating Connector Model Number	Hirose DF19 -20S-1C or compatible

Pin#	Symbol	Pin#	Symbol
1	VDD	11	RxIN2-
2	VDD	12	RxIN2+
3	GND	13	GND
4	SEL68	14	RxCLKIN-
5	RxIN0-	15	RxCLKIN+
6	RxIN0+	16	NC
7	GND	17	U/D
8	RxIN1-	18	R/L
9	RxIN1+	19	RxIN3-
10	GND	20	RxIN3+

#### 7.2 Backlight (CN2)

Recommended connector: BHSR-02VS-1 manufactured by JST.

Pin no	Symbol	I/O	Description	Remark
1	VLED+	P	Backlight LED anode	
2	VLED-	P	Backlight LED cathode	

**8. Reliability Test**

Environment test conditions are listed as following table.

Items	Required Condition	Note
Temperature Humidity Bias (THB)	Ta= 40°C , 90%RH, 300hours	
High Temperature Operation (HTO)	Ta= 80°C , 50%RH, 300hours	3
Low Temperature Operation (LTO)	Ta= -30°C , 300hours	
High Temperature Storage (HTS)	Ta= 80°C , 300hours	
Low Temperature Storage (LTS)	Ta= -30°C , 300hours	
Thermal Shock Test (TST)	-20°C/30min, 60°C/30min, 100 cycles	1
On/Off Test	On/10sec, Off/10sec, 30,000 cycles	
ESD (ElectroStatic Discharge)	Contact Discharge: ± 8KV, 150pF(330Ω ) 1sec, 9 points, 25 times/ point.	2
	Air Discharge: ± 15KV, 150pF(330Ω ) 1sec 9 points, 25 times/ point.	2
Attitude test	Operating: 14,000 ft, Ramp: 2000 ft/min, 8hrs Non-operating: 40,000 ft, Ramp: 2000 ft/min, 24hrs	

Note 1: The TFT-LCD module will not sustain damage after being subjected to 100 cycles of rapid temperature change. A cycle of rapid temperature change consists of varying the temperature from -20°C to 60°C , and back again. Power is not applied during the test. After temperature cycling, the unit is placed in normal room ambient for at least 4 hours before power on.

Note 2: According to EN61000-4-2 , ESD class B: Some performance degradation allowed. No data lost. Self-recoverable. No hardware failures.

Note 3: TFT surface.

9. Shipping Label & Package

(TBD)

Max. capacity: 80 TFT-LCD module per carton (40pcs \* 2 layers)

Max. weight: 16.6 kg per carton

Outside dimension of carton: 425(L)mm\* 386(W)mm\* 430(H)mm

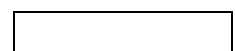
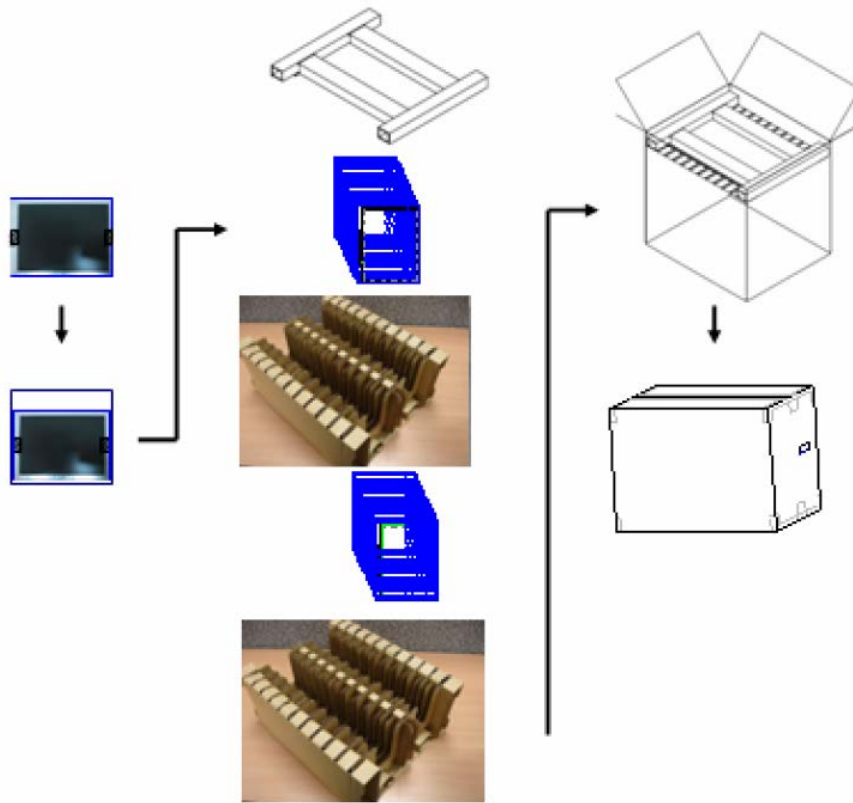

10. Mechanical Characteristic

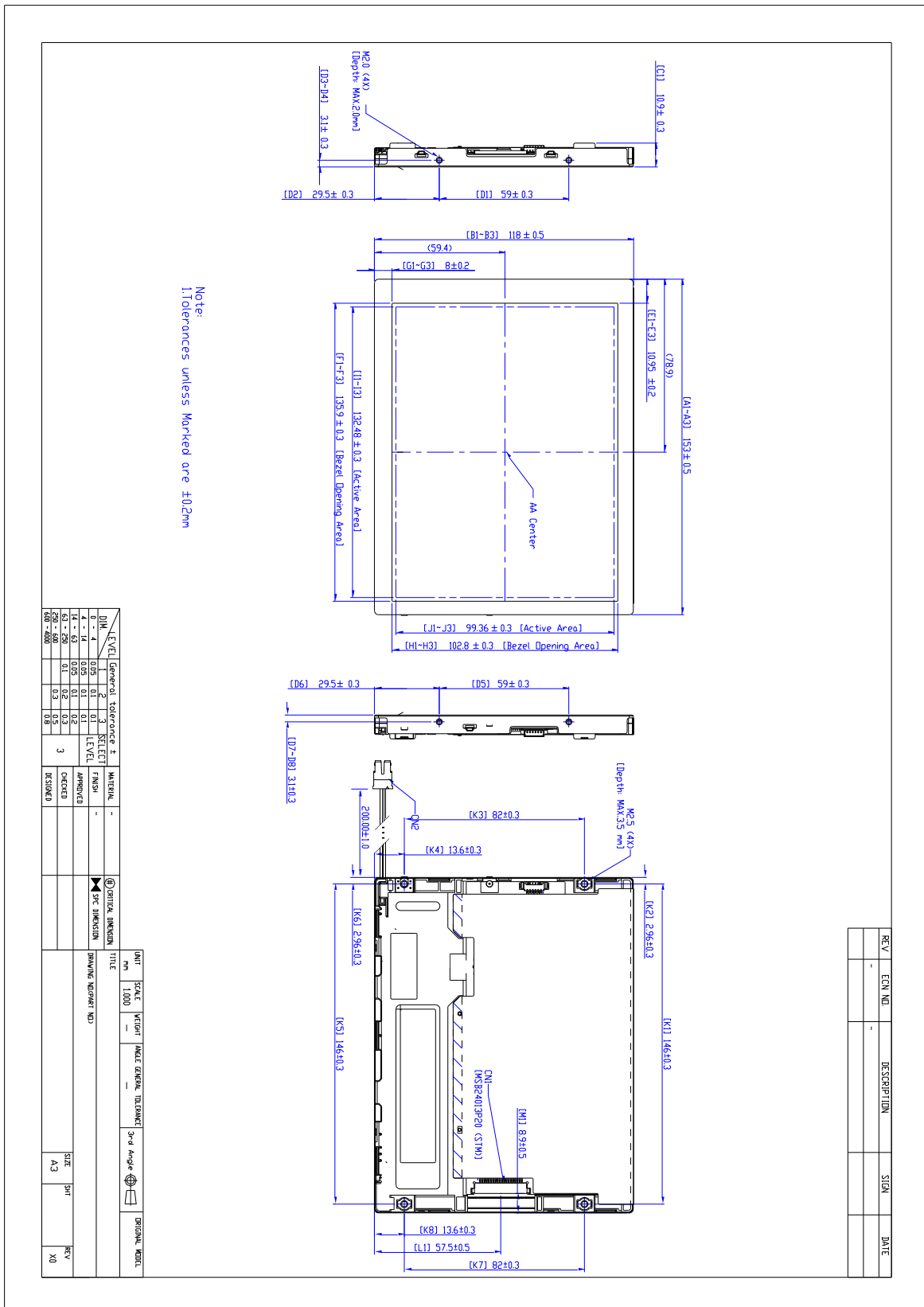

LEVEL	General	Tolerance ±	SELECT	MATERIAL
0 - 4	0.05	0.1	2	-
4 - 53	0.05	0.1	1	LEVEL
53 - 250	0.1	0.2	0.2	APPROVED
250 - 500	0.3	0.3	0.3	CHECKED
500 - 1000	0.5	0.5	0.5	DESIGNED

UNIT	SCALE	WEIGHT	MATERIAL	TOLERANCE	3rd Angle	ORIGINAL	REVISION
mm	1:1000	-	-	-	3rd Angle	ORIGINAL	NO

REV	ECN NO	DESCRIPTION	SIGN	DATE
-	-	-	-	-

