

7.0" WSVGA
High brightness color TFT-LCD module

Model: VM07B5 V8

Version : 01

Date: Nov. 29th, 2021

**Note: This specification is subject to change
without notice**

Customer : _____

Date : _____

Approved

Prepared

Date:

Date:

Contents

1. Handling Precautions

2. General Description

2.1 Overview

2.2 Features

2.3 Application

2.4 Display specifications

2.5 Optical characteristics

3. Absolute Maximum Ratings

3.1 TFT LCD module

3.2 Backlight unit

3.3 Environment

4. Electrical characteristics

4.1 LCD electronics specification

4.1.1 Power specification

4.1.2 Current consumption

4.2 Backlight unit

4.3 Interface connector

4.3.1 TFT connector(CN1)

4.3.2 Backlight connector(CN2)

5. Signal characteristics

5.1 Power sequence

5.2 Timing characteristics

5.2.1 AC electrical characteristics

5.2.2 Input clock and data timing diagram

5.2.3 DC electrical characteristics

5.2.4 Timing

6. Reliability Test

7. Shipping package

8. Mechanical Characteristics

RECORD OF REVISION

Version and Date	Page	Old description	New description	Remark
0.1 2021/11/29	All	First Edition for customer		

1. Handling Precautions

- 1) Since front polarizer is easily damaged, pay attention not to scratch it.
- 2) Be sure to turn off power supply when inserting or disconnecting from input connector.
- 3) Wipe off water drop immediately. Long contact with water may cause discoloration or spots.
- 4) When the panel surface is soiled, wipe it with absorbent cotton or other soft cloth.
- 5) Since the panel is made of glass, it may break or crack if dropped or bumped on hard surface.
- 6) Since CMOS LSI is used in this module, take care of static electricity and insure human earth when handling.
- 7) Do not open or modify the Module Assembly.
- 8) Do not press the reflector sheet at the back of the module to any directions.
- 9) At the insertion or removal of the Signal Interface Connector, be sure not to rotate nor tilt the Interface Connector of the TFT Module.
- 10) After installation of the TFT Module into an enclosure, do not twist nor bend the TFT Module even momentary. At designing the enclosure, it should be taken into consideration that no bending/twisting forces are applied to the TFT Module from outside. Otherwise the TFT Module may be damaged.

2. General Description

2.1 Overview

This specification applies to the Color Active Matrix Liquid Crystal Display composed of a TFT-LCD display a LED backlight system. The screen format is intended to support WSVGA (1024(H) x 600(V)) screen and 262K / 16.7M (6 / 8 bits) color support.

2.2 Features

- High brightness display, 1600nits by LED backlight.
- Long operation lifetime BLU design
- Wide view angle
- Wide operation temperature
- RoHS Compliance

2.3 Application

Industrial applications.

2.4 Display specifications

Items	Unit	Specification
Screen Diagonal	inch	7.0"
Active Area	mm	154.2144 (H) X 85.92 (V)
Pixels H x V	pixels	1024 x3(RGB) x 600
Pixels Pitch	um	150.6 (per one triad) x 143.2
Pixel Arrangement		RGB Vertical stripe
Display mode		Normally white
White luminance (center)	Cd/m ²	1600 (Typ)
Contrast ratio		800:1 (Typ.)
Optical Response Time	msec	25 ms (Typ. On/off)
Normal Input Voltage VDD	Volt	3.3
Power Consumption (Vcc Line + LED backlight)	Watt	6.7 W (VDD line=0.4 W; LED lines= 6.3 W)
Weight	Grams	140
Physical size	mm	164.9 (W)× 100.0 (H)× 4.8 (D)
Electrical Interface		LVDS
Support colors		262K / 16.7M colors (6 / 8 bits)
Source Driver IC		EK79001AX
Gate Driver IC		EK73215BCGA
Surface Treatment		Hard coating
Temperature range		
Operating	°C	-20 ~ 70
Storage	°C	-30 ~ 80
RoHS Compliance		RoHS Compliance

2.5 Optical characteristics

The following optical characteristics are measured under stable condition at 25 °C

Items	Unit	Conditions	Min.	Typ.	Max.	Note
Viewing angle	Deg.	Horizontal (Right)	75	80		2
		CR=10 (Left)	75	80		
		Vertical (Up)	55	60		
		CR=10 (Down)	65	70		
Contrast Ratio		Normal Direction	500	800		3
Response Time	msec	Raising + Falling		25	50	4
Color coordinates (CIE) White		White x	-0.05	0.31	+0.05	5
		White y		0.33		
Center Luminance	Cd/m ²		1300	1600		6
Luminance Uniformity	%		70	75		7
Crosstalk (in 60 Hz)	%				1.5	
Flicker	dB				-20	

Note 1: Measurement method

The LCD module should be stabilized at given temperature for 0.5 hour to avoid abrupt temperature change during measuring. In order to stabilize the luminance, the measurement should be executed after lighting Backlight for 1 hour in a windless room.

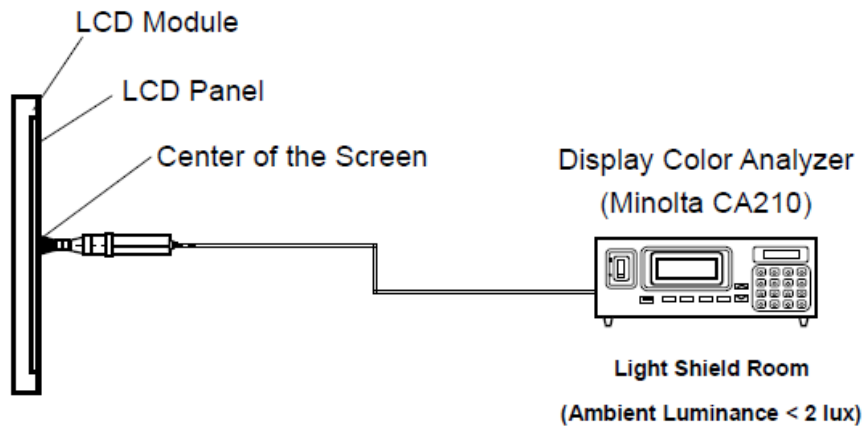

Note 2: Definition of viewing angle

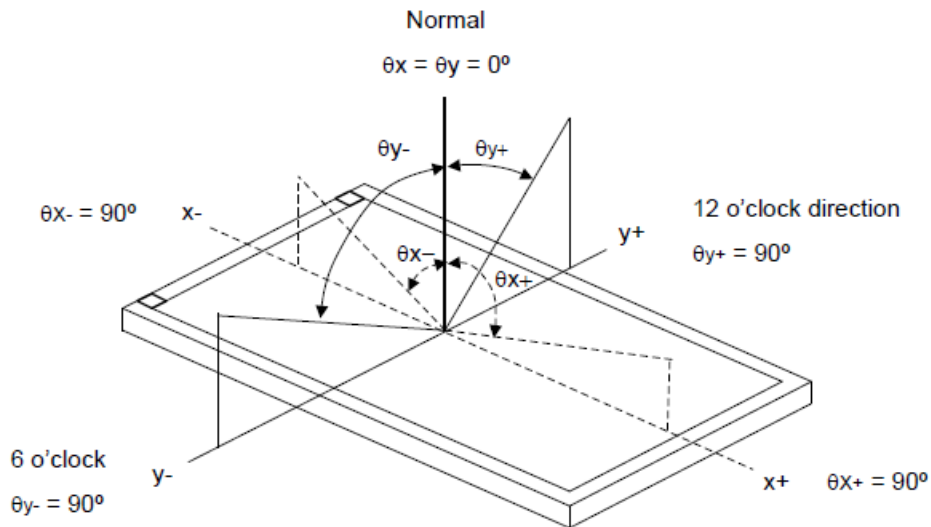

Note 3: Contrast ratio is measured by Minolta CA210

Note 4: Definition of Response time

The output signals of photo detector are measured when the input signals are changed from “Full Black” to “Full White” (rising time), and from “Full White” to “Full Black” (falling time), respectively. The response time is interval between the 10% and 90% of amplitudes. Please refer to the figure as below.

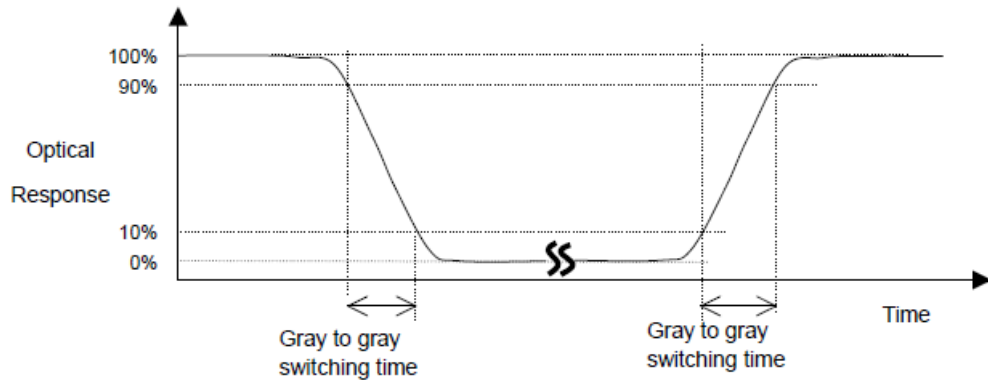

Note 5: Color chromaticity and coordinates (CIE) is measured by Minolta CA210

Note 6: Center luminance is measured by Minolta CA210

Note 7: Luminance uniformity of these 5 points is defined as below and measured by Minolta CA210



$$\text{Uniformity} = (\text{Min. Luminance of 5 points}) / (\text{Max. Luminance of 5 points})$$

3. Absolute Maximum Ratings

Absolute maximum ratings of the module are as following:

3.1 TFT LCD module

Items	Symbol	Min	Max	Unit	Conditions
Power supply voltage	V _{DD}	-0.3	5.0	Volt	Note 1, 2

3.2 Backlight unit

Items	Symbol	Min	Max	Unit	Conditions
LED bar input current			600	mA	

3.3 Environment

Items	Symbol	Values			Unit	Conditions
		Min.	Typ.	Max.		
Operation temperature	T _{OS}	-20	-	70	°C	Note 3
Operation Humidity	H _{OP}	10		85	%	
Storage temperature	T _{ST}	-30		80	°C	
Storage Humidity	H _{ST}	5		90	%	

Note 1: With in Ta= 25°C

Note 2: Permanent damage to the device may occur if exceed maximum values

Note 3: For quality performance, please refer to IIS (Incoming Inspection Standard).

4. Electrical characteristics

4.1 LCD electronics specification

4.1.1 Power specification

(Note 1)

Item	Symbol	Values			Unit	Remark
		Min.	Typ.	Max.		
Power voltage	DV _{DD}	3.0	3.3	3.6	V	Note 2
	AV _{DD}	11.9	12	12.1	V	
	V _{GH}	14.5	15	15.5	V	
	V _{GL}	-10.5	-10	-9.5	V	
Input signal voltage	V _{COM}	4.05	4.55	5.05	V	Note 4
Input logic high voltage	V _{IH}	0.7 DV _{DD}	-	DV _{DD}	V	Note 3
Input logic low voltage	V _{IL}	0	-	0.3 DV _{DD}	V	

Note 1: Be sure to apply DV_{DD} and V_{GL} to the LCD first, and then apply V_{GH}.

Note 2: DV_{DD} setting should match the signals output voltage (refer to Note 3) of customer's system board.

Note 3: LVDS, Reset, [STBYB](#), [SELB](#), [L/R](#), [U/D](#)

Note 4: Typ. V_{COM} is only a reference value, it must be optimized according to each LCM. Be sure to use VR;

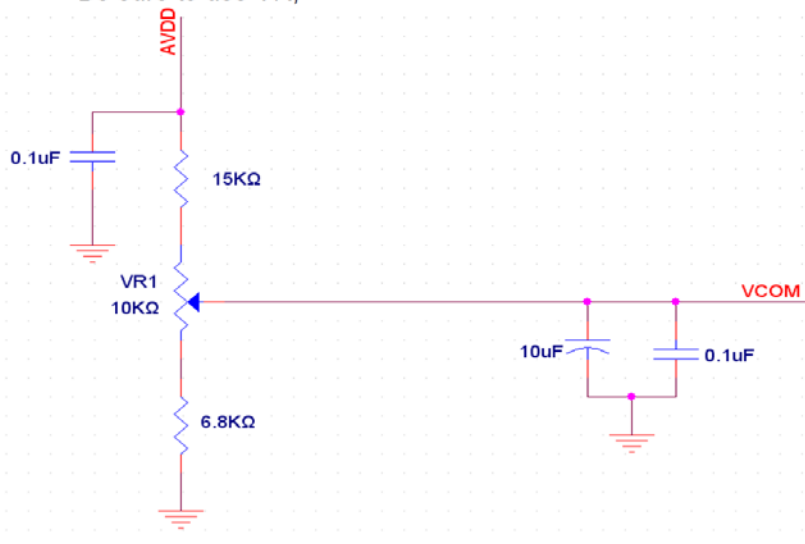

4.1.2 Current consumption

Item	Symbol	Values			Unit	Remark
		Min.	Typ.	Max.		
Current for Driver	I _{GH}	-	0.26	1	mA	V _{GH} =20V
	I _{GL}	-	0.26	1	mA	V _{GL} = -6.8V
	IDV _{DD}	-	35	60	mA	DV _{DD} =3.3V
	I _{AV} _{DD}	-	20	30	mA	AV _{DD} =11V

4.2 Backlight unit

Parameter	Min	Typ	Max	Unit	Note
LED voltage (VL)		18		[V]	2
LED current (IL)		350		[mA]	2
LED power (PL)		6.3		[W]	
LED lite time (MTBF)		100,000		[Hour]	1

Note 1: The “LED lift time” is defined as the module brightness decrease to 50% original brightness that the ambient temperature is 25°C and typical LED Current at 350 mA

Note 2: The variance of LED Light Bar power consumption is ±10%. Calculator value for reference (IL × VL = PLED)

4.3 Interface connector

4.3.1 TFT connector(CN1)

FPC Connector is used for the module electronics interface. The recommended model is FH12A-40S-0.5SH manufactured by Hirose.

Pin No.	Symbol	I/O	Function	Remark
1	VCOM	P	Common Voltage	
2	VDD	P	Power Voltage for digital circuit	
3	VDD	P	Power Voltage for digital circuit	
4	NC	---	No connection	
5	Reset	I	Global reset pin	
6	STBYB	I	Standby mode, Normally pulled high STBYB = "1", normal operation STBYB = "0", timing controller, source driver will turn off, all output are High-Z	
7	GND	P	Ground	
8	RXIN0-	I	- LVDS differential data input	
9	RXIN0+	I	+ LVDS differential data input	
10	GND	P	Ground	
11	RXIN1-	I	- LVDS differential data input	
12	RXIN1+	I	+ LVDS differential data input	
13	GND	P	Ground	
14	RXIN2-	I	- LVDS differential data input	
15	RXIN2+	I	+ LVDS differential data input	
16	GND	P	Ground	
17	RXCLKIN-	I	- LVDS differential clock input	
18	RXCLKIN+	I	+ LVDS differential clock input	
19	GND	P	Ground	
20	RXIN3-	I	- LVDS differential data input	
21	RXIN3+	I	+ LVDS differential data input	

22	GND	P	Ground	
23	NC	---	No connection	
24	NC	---	No connection	
25	GND	P	Ground	
26	NC	---	No connection	
27	NC	---	No connection	
28	SELB	I	6bit/8bit mode select	Note1
29	AVDD	P	Power for Analog Circuit	
30	GND	P	Ground	
31	NC	---	No connection	
32	NC	---	No connection	
33	L/R	I	Horizontal inversion	Note2
34	U/D	I	Vertical inversion	Note2
35	VGL	P	Gate OFF Voltage	
36	NC	---	No connection	
37	NC	---	No connection	
38	VGH	P	Gate ON Voltage	
39	NC	---	No connection	
40	NC	---	No connection	

I: input, O: output, P: Power

Note1: If LVDS input data is 6 bits ,SELB must be set to High;

If LVDS input data is 8 bits ,SELB must be set to Low.

Note2: When L/R="0", set right to left scan direction.

When L/R="1", set left to right scan direction.

When U/D="0", set top to bottom scan direction.

When U/D="1", set bottom to top scan direction.

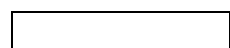

Note: Definition of scanning direction.
Refer to the figure as below:

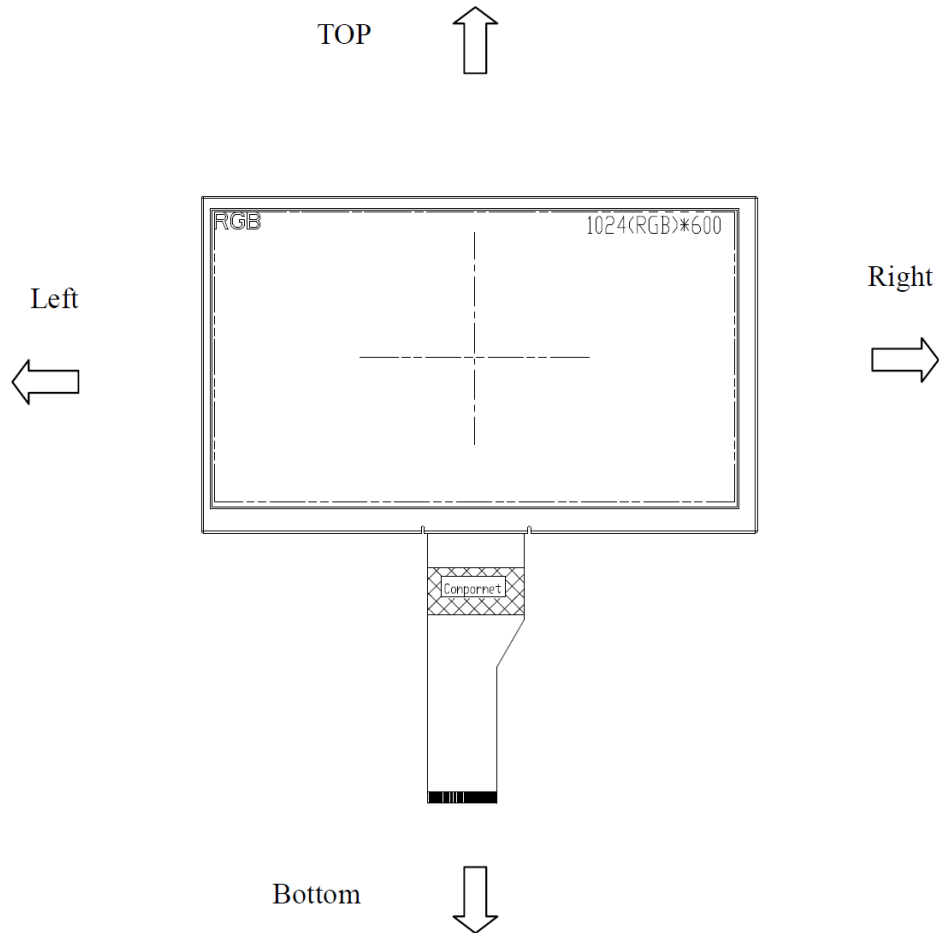

4.3.2 Backlight connector(CN2)

Recommended connector : BHSR-02VS-1 manufactured by JST

Pin no	Symbol	I/O	Description	Remark
1	VLED+	P	Backlight LED anode	Red
2	VLED-	P	Backlight LED cathode	Black

5. Signal characteristics

5.1 Power sequence

a. Power on:

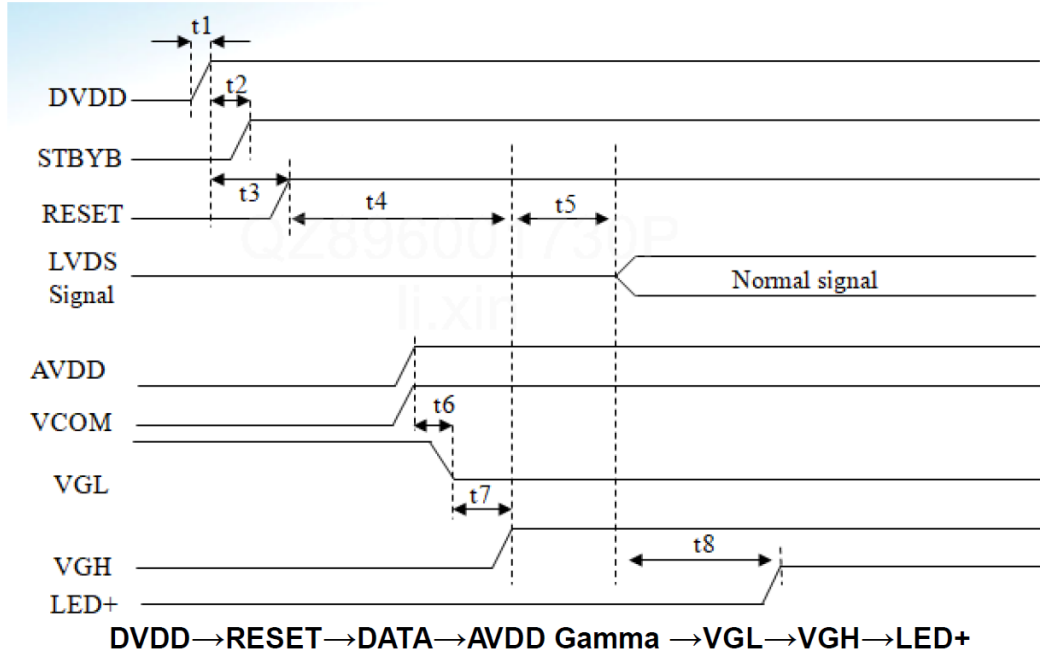

Symbol	SPEC			Unit
	Min.	Typ.	Max.	
t1	0.5	5	20	ms
t2	0	0.25	0.5	ms
t3	1	10(RC Delay)	12	ms
t4	90	-	150	ms
t5	30	-	50	ms
t6	20	-	75	ms
t7	20	-	75	ms
t8	150	-	-	ms

b. Power off:

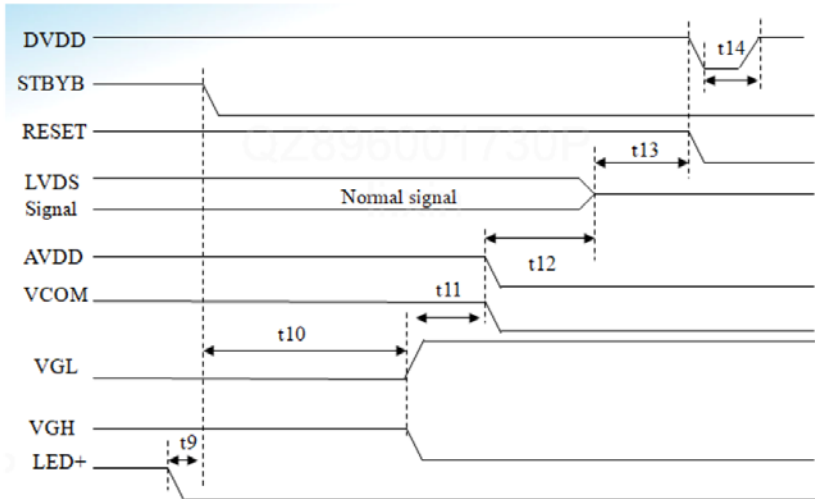

LED+ → VGL/VGH → AVDD Gamma → DATA → RESET → DVDD

Symbol	SPEC			Unit
	Min.	Typ.	Max.	
t9	0.1	1	10	ms
t10	120	150	200	ms
t11	50	100	200	ms
t12	1	10	20	ms
t13	0.1	10	100	ms
t14	500	-	-	ms

5.2 Timing characteristics

5.2.1 AC electrical characteristics

Parameter	Symbol	Values			Unit	Remark
		Min.	Typ.	Max.		
Clock frequency	R _{XFCLK}	40.8	51.2	67.2	MHz	
Input data skew margin	T _{RSKM}	500	900	1200	ps	
Clock high time	T _{LVCH}	3.8/(7* R _{XFCLK})	4/(7* R _{XFCLK})	4.2/(7* R _{XFCLK})	ns	
Clock low time	T _{LVCL}	2.8/(7* R _{XFCLK})	3/(7* R _{XFCLK})	3.2/(7* R _{XFCLK})	ns	

5.2.2 Input clock and data timing diagram

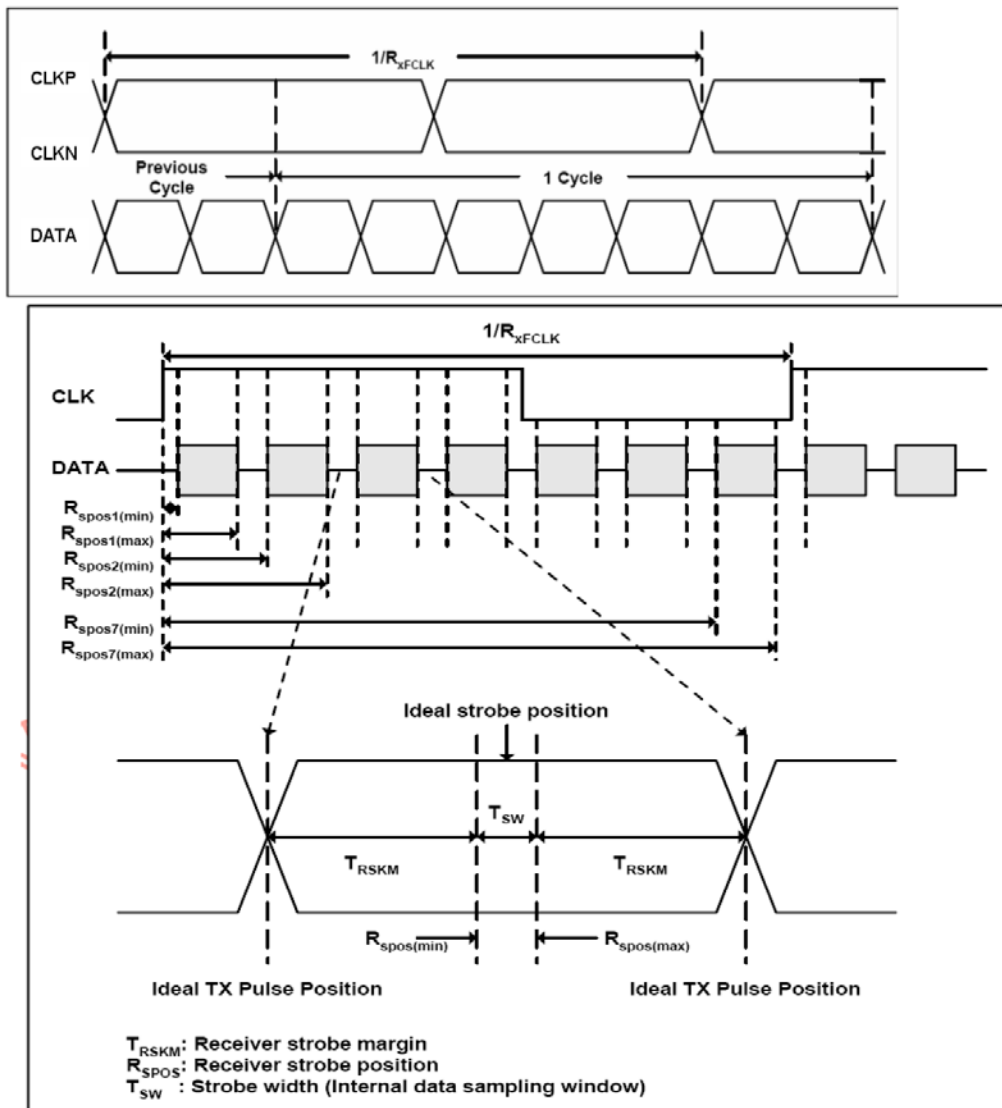

5.2.3 DC electrical characteristics

Parameter	Symbol	Values			Unit	Remark
		Min.	Typ.	Max.		
Differential input high Threshold voltage	R_{xVTH}	-	-	0.1	V	$R_{xVCM}=1.2V$
Differential input low Threshold voltage	R_{xVTL}	-0.1	-	-	V	
Input voltage range (singled-end)	R_{xVIN}	0	-	2.4	V	
Differential input common mode voltage	R_{xVCM}	$ V_{ID} /2$	-	$2.4- V_{ID} /2$	V	
Differential voltage	$ V_{ID} $	0.2	-	0.6	V	
Differential input leakage current	$R_{V_{xIz}}$	-10	-	+10	μA	

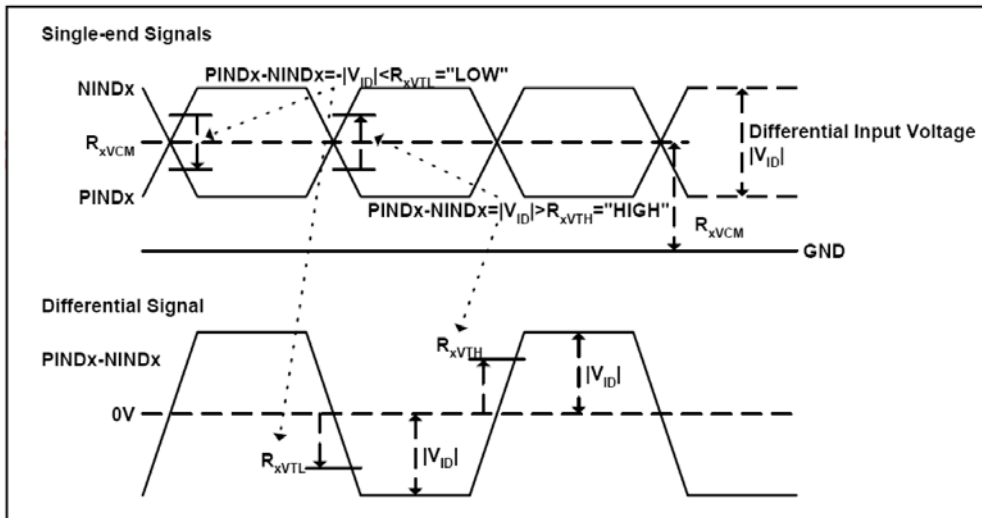

5.2.4 Timing

Item	Symbol	Values			Unit	Remark
		Min.	Typ.	Max.		
Clock Frequency	fclk	40.8	51.2	67.2	MHz	Frame rate =60Hz
Horizontal display area	thd	1024			DCLK	
HS period time	th	1114	1344	1400	DCLK	
HS Blanking	thb	90	320	376	DCLK	
Vertical display area	tvd	600			H	
VS period time	tv	610	635	800	H	
VS Blanking	thb	10	35	200	H	

5.2.5 Data input format

6bit LVDS input

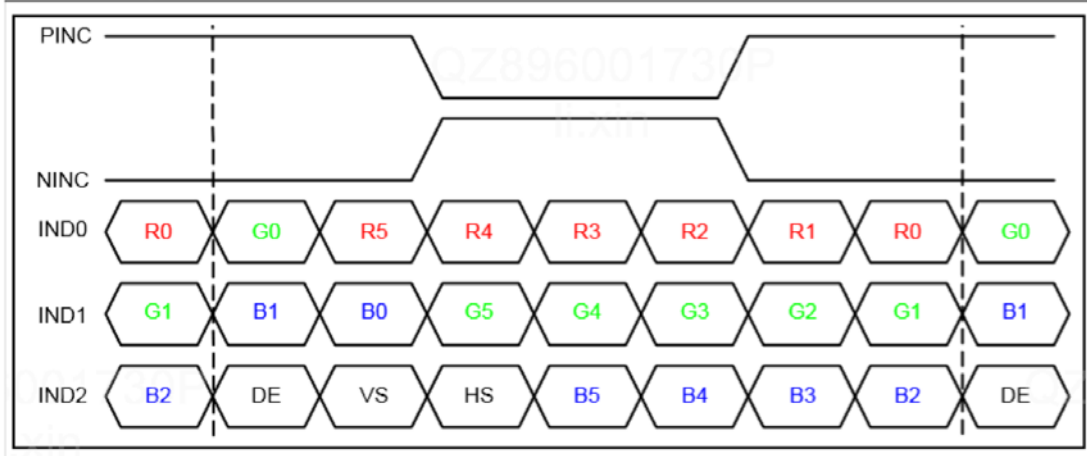

8bit LVDS input

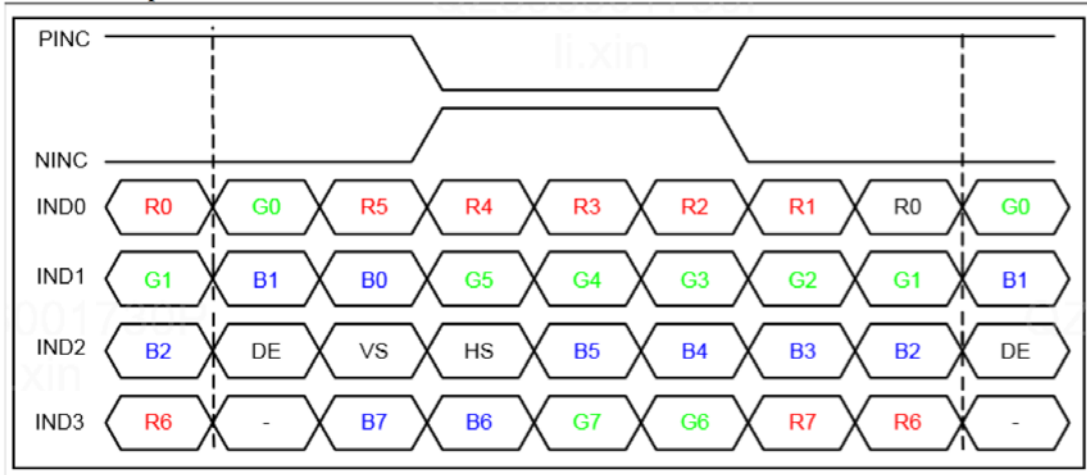

Note: Support DE timing mode only, SYNC mode not supported.

6. Reliability Test

Environment test conditions are listed as following table.

Items	Required Condition	Note
Temperature Humidity Bias (THB)	Ta=40°C, 80%RH, 120hours	
High Temperature Operation (HTO)	Ts= 70°C, 120hours	3
Low Temperature Operation (LTO)	Ta= -20°C, 120hours	
High Temperature Storage (HTS)	Ta= 80°C, 120hours	
Low Temperature Storage (LTS)	Ta= -30°C, 120hours	
Thermal Shock Test (TST)	-20°C/30min, 60°C/30min, 100 cycles	
On/Off Test	On/10sec, Off/10sec, 30,000 cycles	
ESD (ElectroStatic Discharge)	Contact Discharge: ± 8KV, 150pF(330Ω) 1sec, 9 points, 25 times/ point.	
	Air Discharge: ± 15KV, 150pF(330Ω) 1sec 9 points, 25 times/ point.	

Note 1: The TFT-LCD module will not sustain damage after being subjected to 100 cycles of rapid temperature change. A cycle of rapid temperature change consists of varying the temperature from -10°C to 50°C, and back again. Power is not applied during the test. After temperature cycling, the unit is placed in normal room ambient for at least 4 hours before power on.

Note 2: According to EN61000-4-2 , ESD class B: Some performance degradation allowed. No data lost. Self-recoverable. No hardware failures.

Note 3: TFT surface.

7. Shipping package (TBD)

No.	Item	Model (Material)	Dimensions(mm)	Unit Weight (kg)	Quantity (PCS)	Remark
1	LCM	VM07B5 V7	164.90x100x4.8	0.140	50	
2	Dust-Proof Bag	PE	700 x 530x0.05	0.048	1	
3	CrepePaper Tape	四維CM35	30x10x0.1	0.001	50	
4	Corrugated Bar	BC Corrugated paper	510x122	0.046	4	
5	Partition	BC Corrugated paper	512 × 349 × 226	1.466	1	
6	A/S Bag	PE	178*160*0.06	0.004	50	
7	Carton	Corrugated paper	525 × 362 × 250	0.950	1	
8	Total weight	10.12± 5%Kg				

Total LCM quantity in Carton: no. of Partition 2 Rows × quantity per Row 25 = 50

8. Mechanical Characteristics

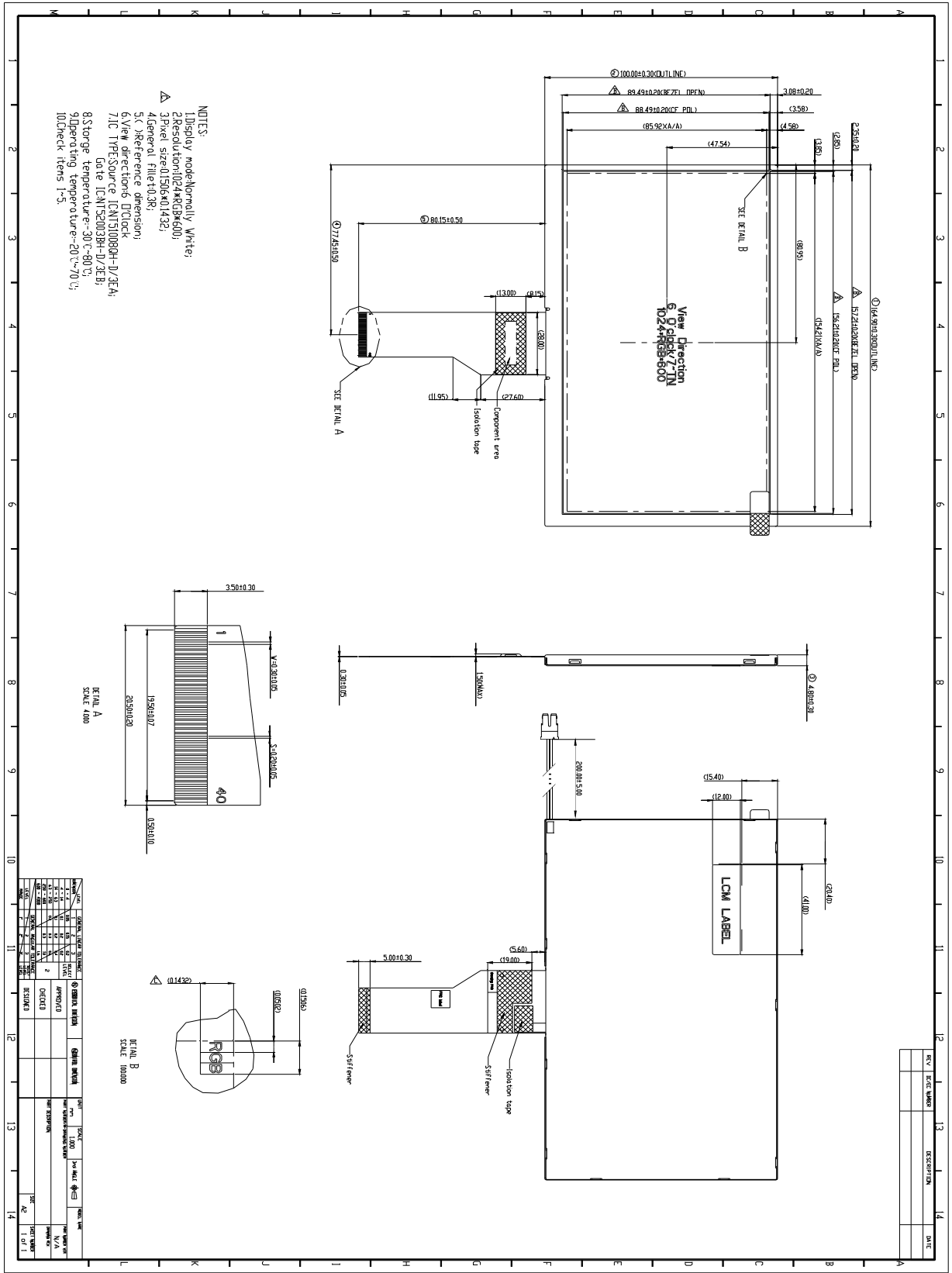

MODEL:
VM07B5 V8

Doc. No:

Preliminary