

**8.0" XGA****High brightness color TFT-LCD module****Model: VM08B6 V7****Date: Aug. 05<sup>th</sup>, 2022****Note: This specification is subject to change  
without notice****Customer :** \_\_\_\_\_**Date :** \_\_\_\_\_**Approved****Prepared****Date:****Date:**

## Contents

- 1. Handling Precautions**
- 2. General Description**
  - 2.1 Overview
  - 2.2 Features
  - 2.3 Application
  - 2.4 Display specifications
  - 2.5 Optical characteristics
- 3. Function block diagram**
- 4. Absolute Maximum Ratings**
  - 4.1 TFT LCD module
  - 4.2 Backlight unit
  - 4.3 Environment
- 5. Electrical characteristics**
  - 5.1 LCD electronics specification
  - 5.2 Backlight unit
  - 5.3 Interface connector
    - 5.3.1 TFT connector(CN1)
    - 5.3.2 Backlight connector(CN2)
- 6. Timing chart**
  - 6.1 LVDS mode DC electrical characteristics
  - 6.2 LVDS mode AC electrical characteristics
  - 6.3 Data input format
    - 6.3.1 LVDS data mapping
    - 6.3.2 Parallel RGB input timing table
  - 6.4 Power ON/OFF sequence
    - 6.4.1 System power ON/OFF sequence
    - 6.4.2 Enter and exit standby mode sequence
- 7. Reliability Test**
- 8. Shipping package**
- 9. Mechanical Characteristics**

## RECORD OF REVISION

Version and Date	Page	Old description	New description	Remark
0.1 2022/08/05	All	First Edition for customer		

## 1. Handling Precautions

- 1) Since front polarizer is easily damaged, pay attention not to scratch it.
- 2) Be sure to turn off power supply when inserting or disconnecting from input connector.
- 3) Wipe off water drop immediately. Long contact with water may cause discoloration or spots.
- 4) When the panel surface is soiled, wipe it with absorbent cotton or other soft cloth.
- 5) Since the panel is made of glass, it may break or crack if dropped or bumped on hard surface.
- 6) Since CMOS LSI is used in this module, take care of static electricity and insure human earth when handling.
- 7) Do not open or modify the Module Assembly.
- 8) Do not press the reflector sheet at the back of the module to any directions.
- 9) At the insertion or removal of the Signal Interface Connector, be sure not to rotate nor tilt the Interface Connector of the TFT Module.
- 10) After installation of the TFT Module into an enclosure, do not twist nor bend the TFT Module even momentary. At designing the enclosure, it should be taken into consideration that no bending/twisting forces are applied to the TFT Module from outside. Otherwise the TFT Module may be damaged.

## 2. General Description

### 2.1 Overview

This specification applies to the Color Active Matrix Liquid Crystal Display composed of a TFT-LCD display a LED backlight system. The screen format is intended to support XGA (1024(H) x 768(V)) screen and 16.7M colors.

### 2.2 Features

- High brightness display, 1500nits by LED backlight.
- Wide operation temperature.
- Long operation lifetime BLU design
- RoHS Compliance

### 2.3 Application

Industrial applications.

### 2.4 Display specifications

Items	Unit	Specification
Screen Diagonal	mm	8.0
Active Area	mm	162.05 (H) X 121.54 (V)
Pixels H x V	pixels	1024 x3(RGB) x 768
Pixels Pitch	um	158 (per one triad) x 158
Pixel Arrangement		RGB Vertical stripe
Display mode		Normally Black
White luminance (center)	Cd/m <sup>2</sup>	1500 (Typ)
Contrast ratio		1200:1 (Typ.)
Optical Response Time	msec	35 ms (Typ. On/off)
Normal Input Voltage VDD	Volt	3.3
Power Consumption (Vcc Line + LED backlight)	Watt	TBDW (VDD line=TBD W; LED lines= 4.32 W)
Weight	Grams	TBD
Physical size	mm	183.43 (W)×138.35 (H)×3.75 (D)
Electrical Interface		LVDS
Support colors		16.7M colors
Surface Treatment		Anti-glare and hard-coating 3H
Temperature range		
Operating	°C	-20 ~ 70 (TFT surface)
Storage	°C	-30 ~ 80
RoHS Compliance		RoHS Compliance

### 2.5 Optical characteristics

The following optical characteristics are measured under stable condition at 25 °C

Items	Unit	Conditions	Min.	Typ.	Max.	Note
Viewing angle	Deg.	Horizontal (Right)	75	85		2
		CR=10 (Left)	75	85		
		Vertical (Up)	75	85		
		CR=10 (Down)	75	85		
Contrast Ratio		Normal Direction	1000	1200		3
Response Time	msec	Raising + Falling		35	45	4
Color / Chromaticity Coordinates (CIE)		Red x	-0.05	0.587	+0.05	5
		Red y		0.330		
		Green x		0.358		
		Green y		0.586		
		Blue x		0.156		
		Blue y		0.098		
Color coordinates (CIE) White		White x		0.310		
		White y		0.329		
Center Luminance	Cd/m <sup>2</sup>		1200	1500		6
Luminance Uniformity	%		70	75		7
Crosstalk (in 60 Hz)	%				1.5	
Flicker	dB				-20	

**Note 1: Measurement method**

The LCD module should be stabilized at given temperature for 0.5 hour to avoid abrupt temperature change during measuring. In order to stabilize the luminance, the measurement should be executed after lighting Backlight for 1 hour in a windless room.

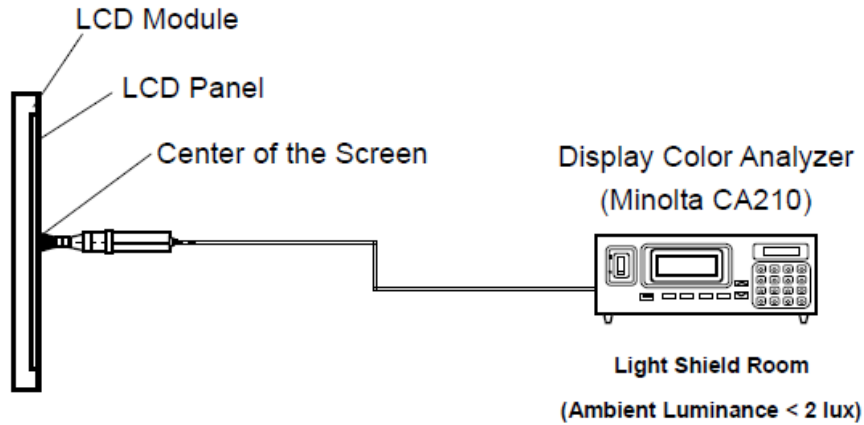

**Note 2: Definition of viewing angle**

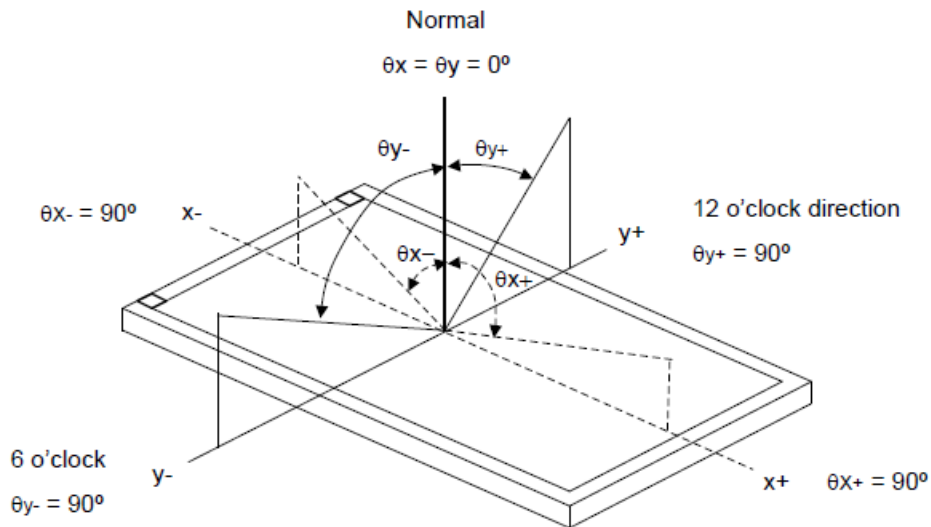

**Note 3: Contrast ratio is measured by Minolta CA210**



**Note 4: Definition of Response time**

The output signals of photo detector are measured when the input signals are changed from “Full Black” to “Full White” (rising time), and from “Full White” to “Full Black” (falling time), respectively. The response time is interval between the 10% and 90% of amplitudes. Please refer to the figure as below.

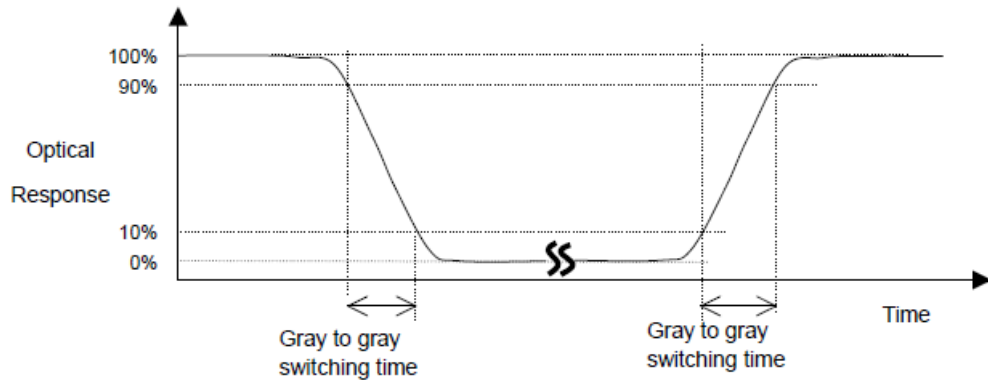

Note 5: Color chromaticity and coordinates (CIE) is measured by Minolta CA210

Note 6: Center luminance is measured by Minolta CA210

Note 7: Luminance uniformity of these 5 points is defined as below and measured by Minolta CA210



$$\text{Uniformity} = (\text{Min. Luminance of 5 points}) / (\text{Max. Luminance of 5 points})$$

**3. Function block diagram**

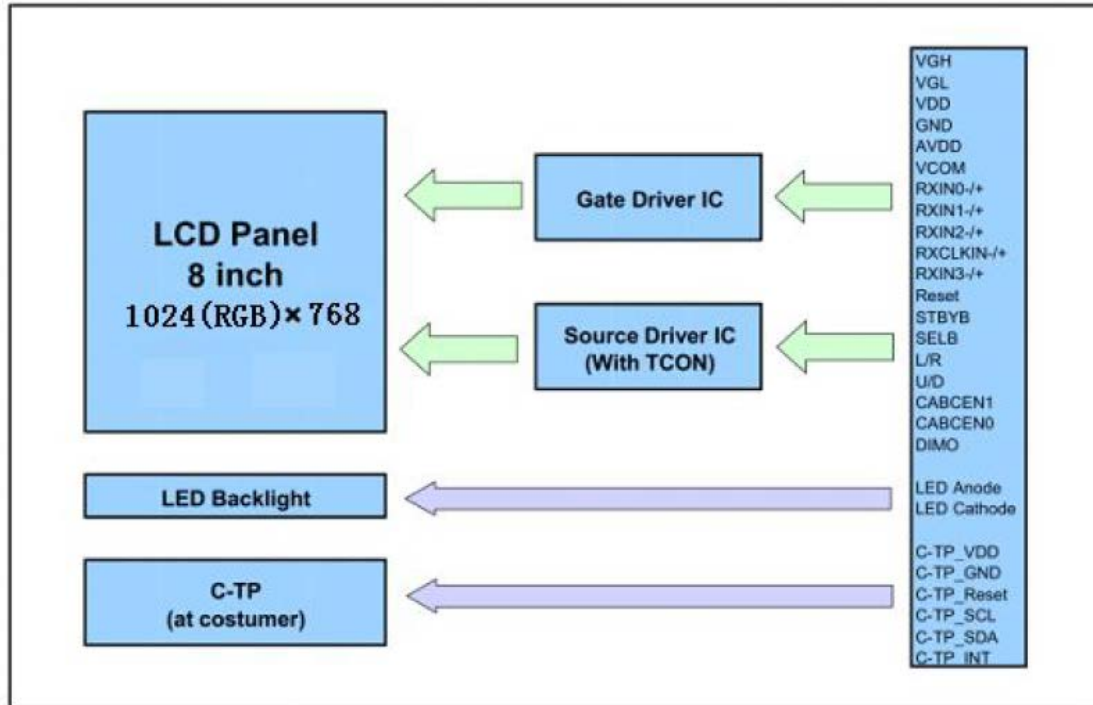

### 4. Absolute Maximum Ratings

Absolute maximum ratings of the module are as following:

#### 4.1 TFT LCD module

Items	Symbol	Min	Max	Unit	Conditions
Power supply voltage	V <sub>DD</sub>	-0.3	5.0	Volt	Note 1, 2

#### 4.2 Backlight unit

Items	Symbol	Min	Max	Unit	Conditions
LED bar input current			600	mA	

#### 4.3 Environment

Items	Symbol	Values			Unit	Conditions
		Min.	Typ.	Max.		
Operation temperature	T <sub>OS</sub>	-20	-	70	°C	Note 3
Operation Humidity	H <sub>OP</sub>	10		85	%	
Storage temperature	T <sub>ST</sub>	-30		80	°C	
Storage Humidity	H <sub>ST</sub>	5		90	%	

Note 1: With in Ta= 25°C

Note 2: Permanent damage to the device may occur if exceed maximum values

Note 3: For quality performance, please refer to IIS (Incoming Inspection Standard).

### 5. Electrical characteristics

#### 5.1 LCD electronics specification

AGND=GND=0V, Ta = 25°C

Item	Symbol	Min	Typ.	Max	Unit	Remark
Digital Supply Voltage	DVDD	3.0	3.3	3.6	V	-
Analog Supply Voltage	AVDD	12.4	12.6	12.8	V	-
Gate On Voltage	VGH	22.0	23.0	24.0	V	-
Gate Off Voltage	VGL	-7.5	-7.0	-6.5	V	-

AGND=GND=0V, Ta = 25°C

Item	Symbol	Condition	Min	Typ.	Max	Unit	Remark
Digital Supply Current	I <sub>VCC</sub>	DVDD=3.3V	-	TBD	-	mA	-
Analog Supply Current	I <sub>AVDD</sub>	AVDD=11.5V	-	TBD	-	mA	-
Gate On Current	I <sub>VGH</sub>	VGH=20.0V	-	TBD	-	mA	-
Gate Off Current	I <sub>VGL</sub>	VGL=-7.0V	-	TBD	-	mA	-
Power Consumption	Pane I & Gamma		-	TBD	-	mW	-

Note1: Checkered Black pattern for Typ.

## 5.2 Backlight unit

Parameter	Min	Typ	Max	Unit	Note
LED voltage (VL)		18		[V]	2
LED current (IL)		240		[mA]	2
LED power (PL)		4.32		[W]	
LED lite time (MTBF)		100,000		[Hour]	1

Note 1: The "LED lift time" is defined as the module brightness decrease to 50% original brightness that the ambient temperature is 25°C and typical LED Current at 240 mA

Note 2: The variance of LED Light Bar power consumption is ±10%. Calculator value for reference ( $IL \times VL = PLED$ )

### 5.3 Interface connector

#### 5.3.1 TFT connector(CN1)

Matched connector:FH12A-40S-0.5SH

Pin No.	Symbol	I/O	Function	Remark
1	NC	-	No connection	
2	VDD	P	Power Voltage for digital circuit	
3	VDD	P	Power Voltage for digital circuit	
4	NC	---	No connection	
5	Reset	I	Global reset pin	
6	STBYB	I	Standby mode, Normally pulled high STBYB = "1", normal operation STBYB = "0", timing controller, source driver will turn off, all output are GND	
7	GND	P	Ground	
8	RXIN0-	I	- LVDS differential data input	
9	RXIN0+	I	+ LVDS differential data input	R[0]~G[0]
10	GND	P	Ground	
11	RXIN1-	I	- LVDS differential data input	
12	RXIN1+	I	+ LVDS differential data input	G[1]~B[1]
13	GND	P	Ground	
14	RXIN2-	I	- LVDS differential data input	
15	RXIN2+	I	+ LVDS differential data input	DE/VS/HS/ B[2]~B[5]
16	GND	P	Ground	
17	RXCLKIN-	I	- LVDS differential clock input	
18	RXCLKIN+	I	+ LVDS differential clock input	
19	GND	P	Ground	
20	RXIN3-	I	- LVDS differential data input	
21	RXIN3+	I	+ LVDS differential data input	R[6]/R[7]/G[6]/G[7]/B[6]/B[7]
22	GND	P	Ground	
23	NC	---	No connection	
24	NC	---	No connection	
25	GND	P	Ground	
26	NC	---	No connection	
27	DIMO	O	Backlight CABC controller signal output	Note1
28	SELB	I	6bit/8bit mode select No	Note2
29	AVDD	P	Power for Analog Circuit	
30	GND	P	Ground	
31	NC	---	No connection	
32	NC	---	No connection	
33	L/R	I	Horizontal inversion	Note3
34	U/D	I	Vertical inversion N	Note3
35	VGL	P	Gate OFF Voltage	
36	CABCEN1	I	CABC H/W enable pin	Note4
37	CABCEN0	I	CABC H/W enable pin	Note4
38	VGH	P	Gate ON Voltage	
39	NC	---	No connection	
40	NC	---	No connection	

I/O----definition, I----Input, O----Output, P----Power, No used I/O pin please fix to GND level

Note1: PWM output after CABC function;

Note2: LVDS mode 6bits/8bits input select pin,If LVDS input data in 6 bits,SELB must be set To high,If LVDS input data in 8 bits,SELB must be set to low,

Note3: When L/R="0",set right to left scan direction, L/R="1" set left to right scan direction

When U/D="0",set top to bottom scan direction, U/D="1" set bottom to top scan direction

Note4:

CABC_EN[1:0]	I	CABC H/W enable pin. Normally pull low. When CABC_EN="00", CABC off. (Default mode) When CABC_EN="01", user interface Image. When CABC_EN="10", still Picture. When CABC_EN="11", moving Image.
--------------	---	---

## 5.3.2 Backlight connector(CN2)

Recommended connector : BHSR-02VS-1 manufactured by JST

Pin no	Symbol	I/O	Description	Remark
1	VLED+	P	Backlight LED anode	Red
2	VLED-	P	Backlight LED cathode	Black



**6. Timing chart**

6.1 LVDS mode DC electrical characteristics

Parameter	Symbol	Min.	Spec. Typ.	Max.	Unit	Condition
Differential input high Threshold voltage	$R_{xVTH}$	-	-	+0.1	V	$R_{xVCM}=1.2V$
Differential input low threshold voltage	$R_{xVTL}$	-0.1	-	-	V	
Input voltage range (singled-end)	$R_{xVIN}$	0	-	$VDD-1.2+ V_{IO} /2$	V	-
Differential input common Mode voltage	$R_{xVCM}$	$ V_{IO} /2$	-	$VDD-1.2$	V	-
Differential input voltage	$ V_{IO} $	0.2	-	0.6	V	-
Differential input leakage Current	$R_{V_{IL2}}$	-10	-	+10	$\mu A$	-
LVDS Digital Operating Current	$I_{ddLVDS}$	-	15	30	mA	Fclk=65MHz, VDD=3.3V
LVDS Digital Stand-by Current	$I_{stLVDS}$	-	10	50	$\mu A$	Clock & all Functions are stopped

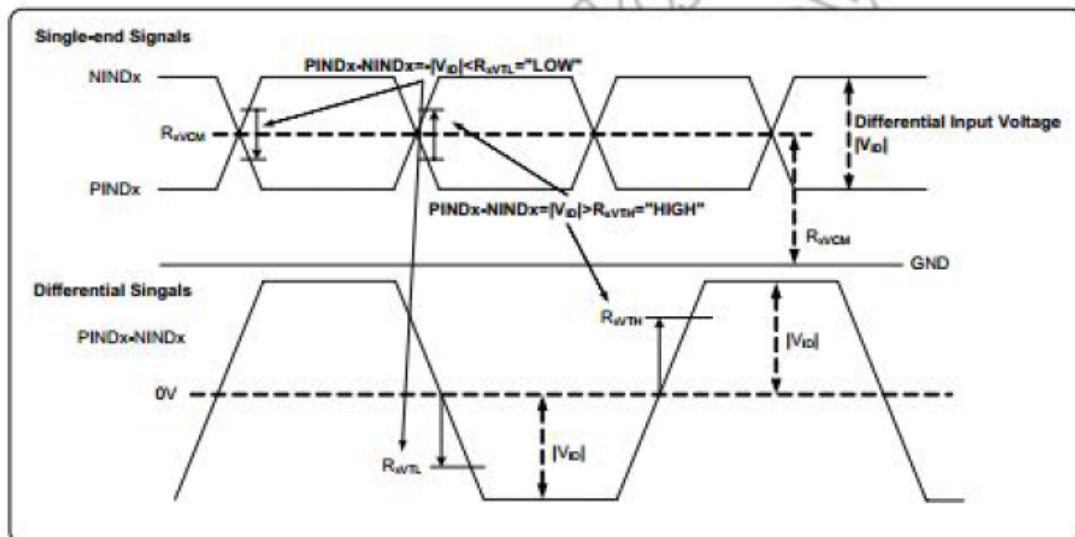

### 6.2LVDS mode AC electrical characteristics

Parameter	Symbol	Min.	Spec. Typ.	Max.	Unit	Condition
Clock frequency	$R_{XFCLK}$	20	-	71	MHz	-
Input data skew margin	$T_{RSKM}$	500	-	-	pS	$ V_{ID} =400mV$ $R_{XVCM}=1.2V$ $R_{XFCLK}=71MHz$
Clock high time	$T_{LVCH}$	-	$4/(7 \cdot R_{XFCLK})$	-	ns	-
Clock low time	$T_{LVCL}$	-	$3/(7 \cdot R_{XFCLK})$	-	ns	-
PLL wake-up time	$T_{enPLL}$	-	-	150	$\mu s$	-

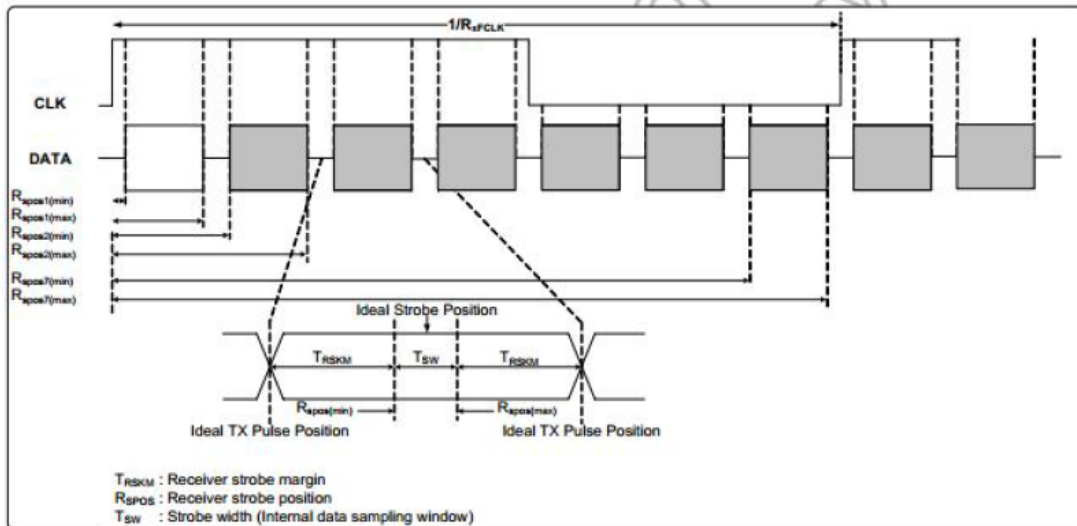
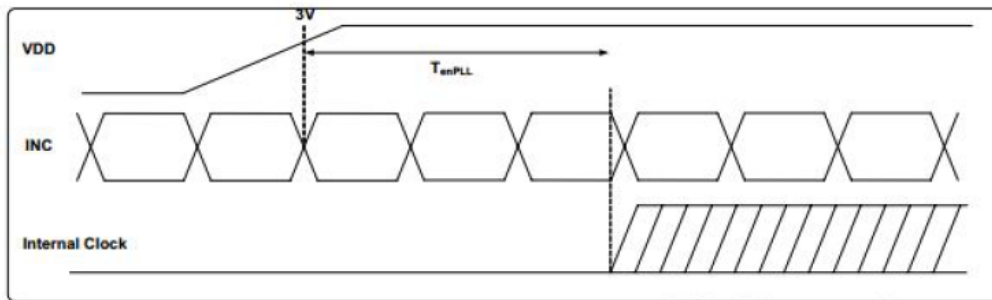
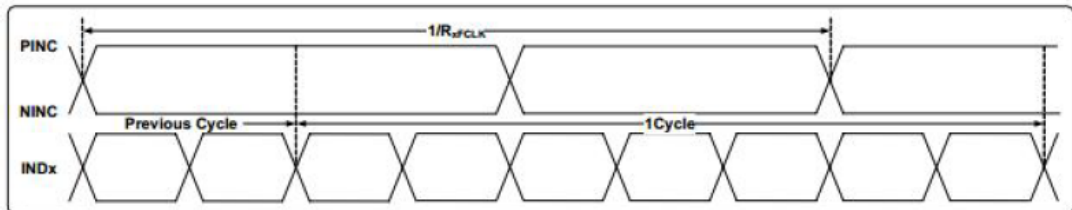

Parameter	Symbol	Min.	Spec. Typ.	Max.	Unit	Condition
Modulation Frequency	$SSC_{MF}$	23	-	93	KHz	-
Modulation Rate	$SSC_{MR}$	-	-	$\pm 3$	%	LVDS clock =71MHz center spread

### 6.3 Data input format

#### 6.3.1 LVDS data mapping

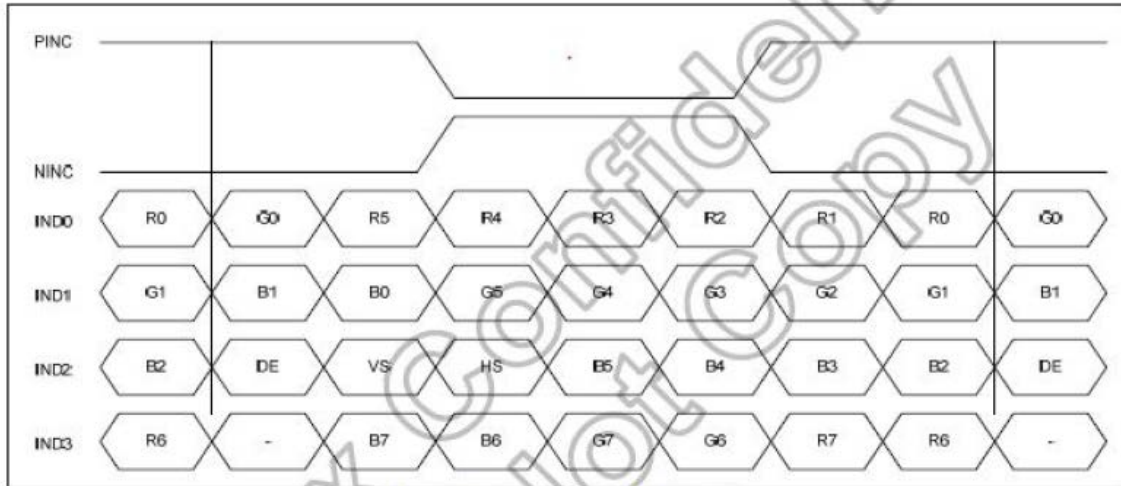

### 6.3.2 Parallel RGB input timing table

- **DE mode**

Parameter	Symbol	Spec.			Unit
		Min.	Typ.	Max.	
DCLK Frequency	fclk	52	65	71	MHz
Horizontal Display Area	thd	1024			DCLK
HSD Period	th	1114	1344	1400	DCLK
HSD Blanking	thb+ thfp	90	320	376	DCLK
Vertical Display Area	tvd	768			T <sub>H</sub>
VSD Period	tv	778	806	845	T <sub>H</sub>
VSD Blanking	tvbp+ tvfp	10	38	77	T <sub>H</sub>

DE mode (1024x768)

- **HV mode**

#### Horizontal timing

Parameter	Symbol	Spec.			Unit
		Min.	Typ.	Max.	
DCLK Frequency	fclk	57	65	70.5	MHz
Horizontal Display Area	thd	1024			DCLK
HSD Period	th	1200	1344	1400	DCLK
HSD Pulse Width	thpw	1	140		DCLK
HSD Back Porch	thbp	160			DCLK
HSD Front Porch	thfp	16	160	216	DCLK

HV mode horizontal timing (1024x768)

#### Vertical timing

Parameter	Symbol	Spec.			Unit
		Min.	Typ.	Max.	
Vertical Display Area	tvd	768			T <sub>H</sub>
VSD Period	tv	792	806	840	T <sub>H</sub>
VSD Pulse Width	tvpw	1	-	20	T <sub>H</sub>
VSD Back Porch	tvbp	23			T <sub>H</sub>
VSD Front Porch	tvfp	1	15	49	T <sub>H</sub>

HV mode vertical timing (1024x768)

6.4 Power ON/OFF sequence

6.4.1 System power ON/OFF sequence

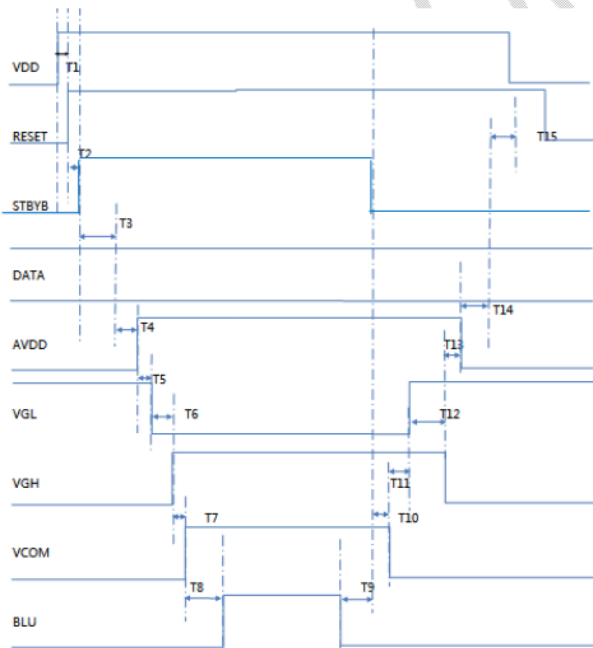
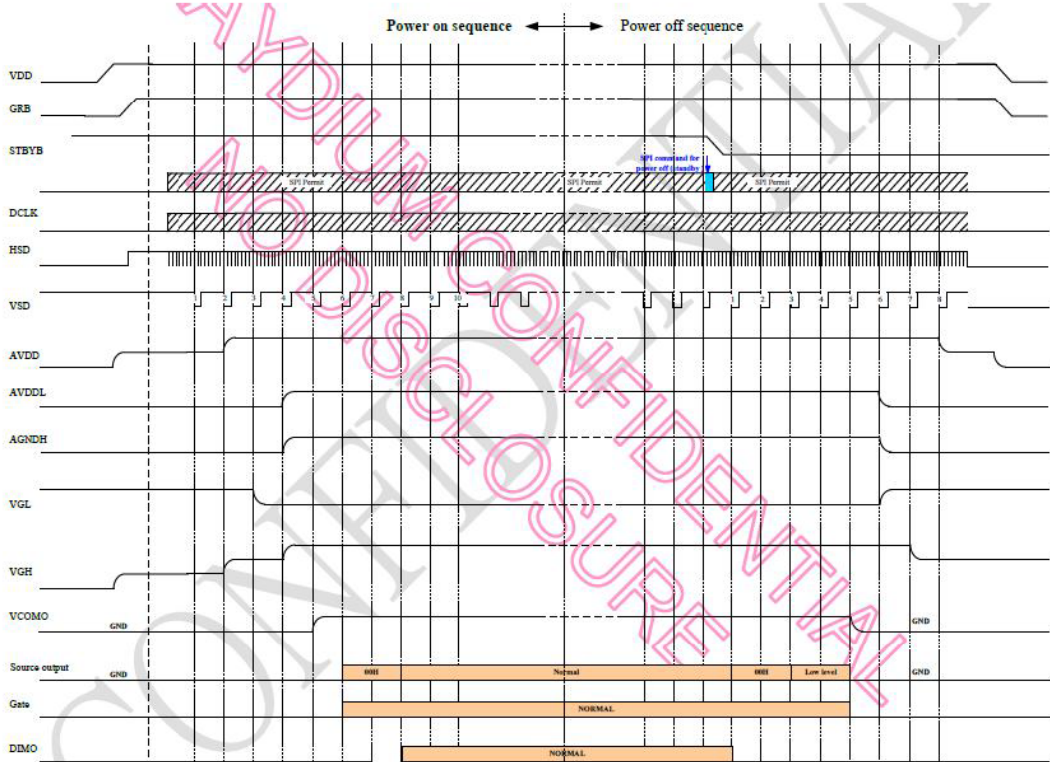

power on/off seque	Min	Typ	Max	Unit
T1	1			
T2	0			
T3	1			
T4	33.2			
T5	16.6			
T6	16.6			
T7	16.6			
T8	200			ms
T9	500			
T10	83			
T11	16.6			
T12	16.6			
T13	16.6			
T14	16.6			
T15	16.6			



6.4.2 Enter and exit standby mode sequence

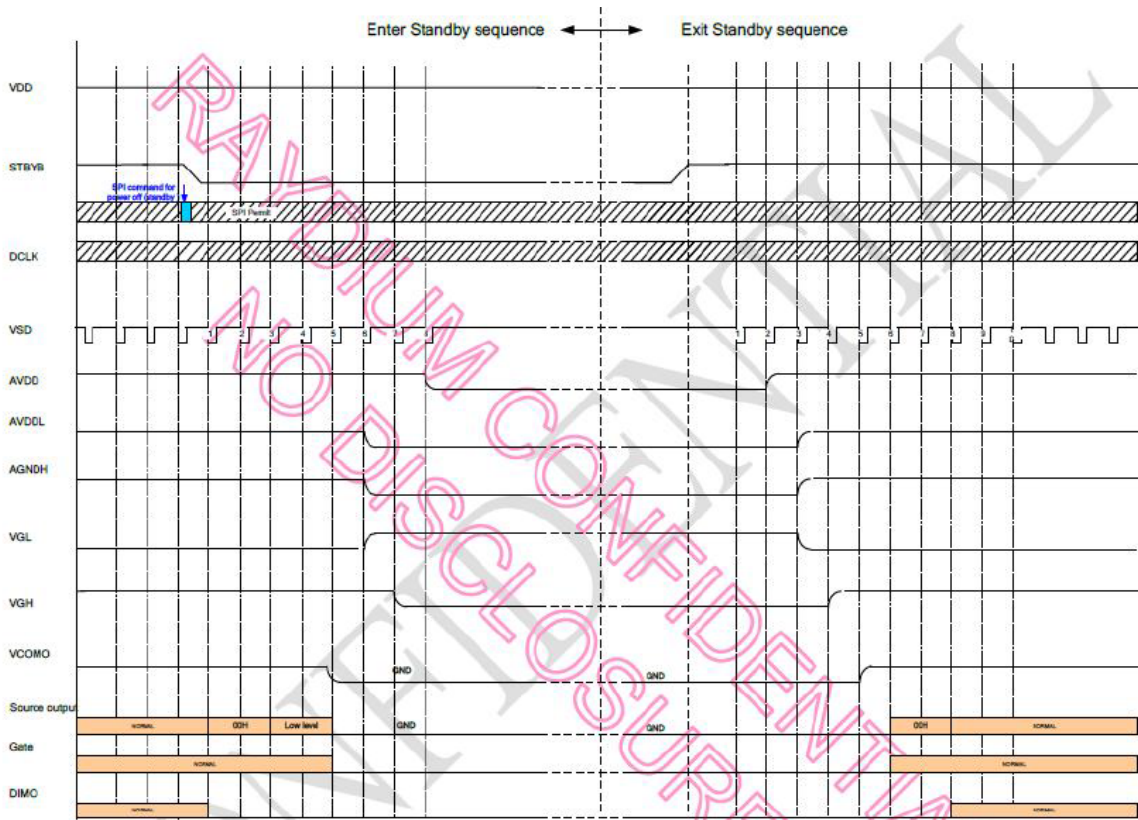

Note : Low level = 3FH, when NBW = L ( Normally white )  
 Low level = 00H, when NBW = H ( Normally block )

### 7. Reliability Test

Environment test conditions are listed as following table.

Items	Required Condition	Note
Temperature Humidity Bias (THB)	Ta=40°C, 80%RH, 240hours	
High Temperature Operation (HTO)	Ts= 70°C, 240hours	3
Low Temperature Operation (LTO)	Ta= -20°C, 240hours	
High Temperature Storage (HTS)	Ta= 80°C, 240hours	
Low Temperature Storage (LTS)	Ta= -30°C, 240hours	
Thermal Shock Test (TST)	-20°C/30min, 60°C/30min, 100 cycles	
On/Off Test	On/10sec, Off/10sec, 30,000 cycles	
ESD (ElectroStatic Discharge)	Contact Discharge: ± 4KV, 150pF(330Ω ) 1sec/cycle	
	Air Discharge: ± 8KV, 150pF(330Ω ) 1sec/cycle	

Note 1: The TFT-LCD module will not sustain damage after being subjected to 100 cycles of rapid temperature change. A cycle of rapid temperature change consists of varying the temperature from -10°C to 50°C, and back again. Power is not applied during the test. After temperature cycling, the unit is placed in normal room ambient for at least 4 hours before power on.

Note 2: According to EN61000-4-2 , ESD class B: Some performance degradation allowed. No data lost. Self-recoverable. No hardware failures.

Note 3: TFT surface.

### 8. Shipping package

No	Item	Model (Material)	Dimensions(mm)	Unit Weight(Kg)	Quantity	Remark
1	LCM module		183.43×138.35×3.75	TBD	48	
2	Beauty-grain	Tape	30×10	TBD	96	
3	Partition_1	Corrugated paper	527×348×217	1.323	1	
4	Anti-static Bubble Bag	PE	231×200×3.0	TBD	48	Anti-static
5	Dust-Proof Bag	PE	700×545	0.06	1	
6	Partition_2	Corrugated Paper	505×332×4.0	0.098	2	
7	Corrugated Bar	Corrugated paper	348×173	0.028	6	
8	Carton	Corrugated paper	544×365×250	1.12	1	
9	Total weight	TBD				

Put the module into the Anti-static bag.

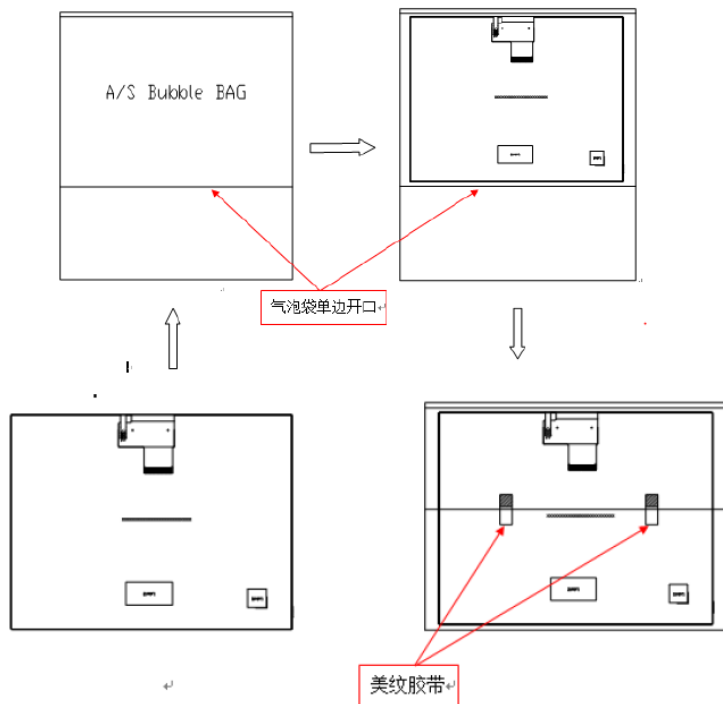



**9. Mechanical Characteristics**

